

NO	PART NAME	Q'TY	MATERIAL	NOTE	PART NO.
02	FRONT CASING	1	PPG	HOSE THREAD	1001005100
01	MOTOR	1	150W,2P	100~120V 200~240V	1001006100 1001098100 1001000100

10	SET SCREW	2	S435	M6X10	
09	HEXAGON HEAD BOLT w/t PLAIN WASHER	6	SUS304	M6X55	
08	O. RING	1	FKM	G110	1001001300
07	BACK UP RING	1	SUS304	φ98X4.5	1001008600
06	BEARING	1	CERAMIC	φ25X35	
05	OUTER DRIVE RING	1	ADC-12 RULON		1001000900
04	IMPELLER ASS'Y	1	PPG	φ86X86	1003411800
03	REAR CASING	1	PPS	φ123.5X75	1001000500

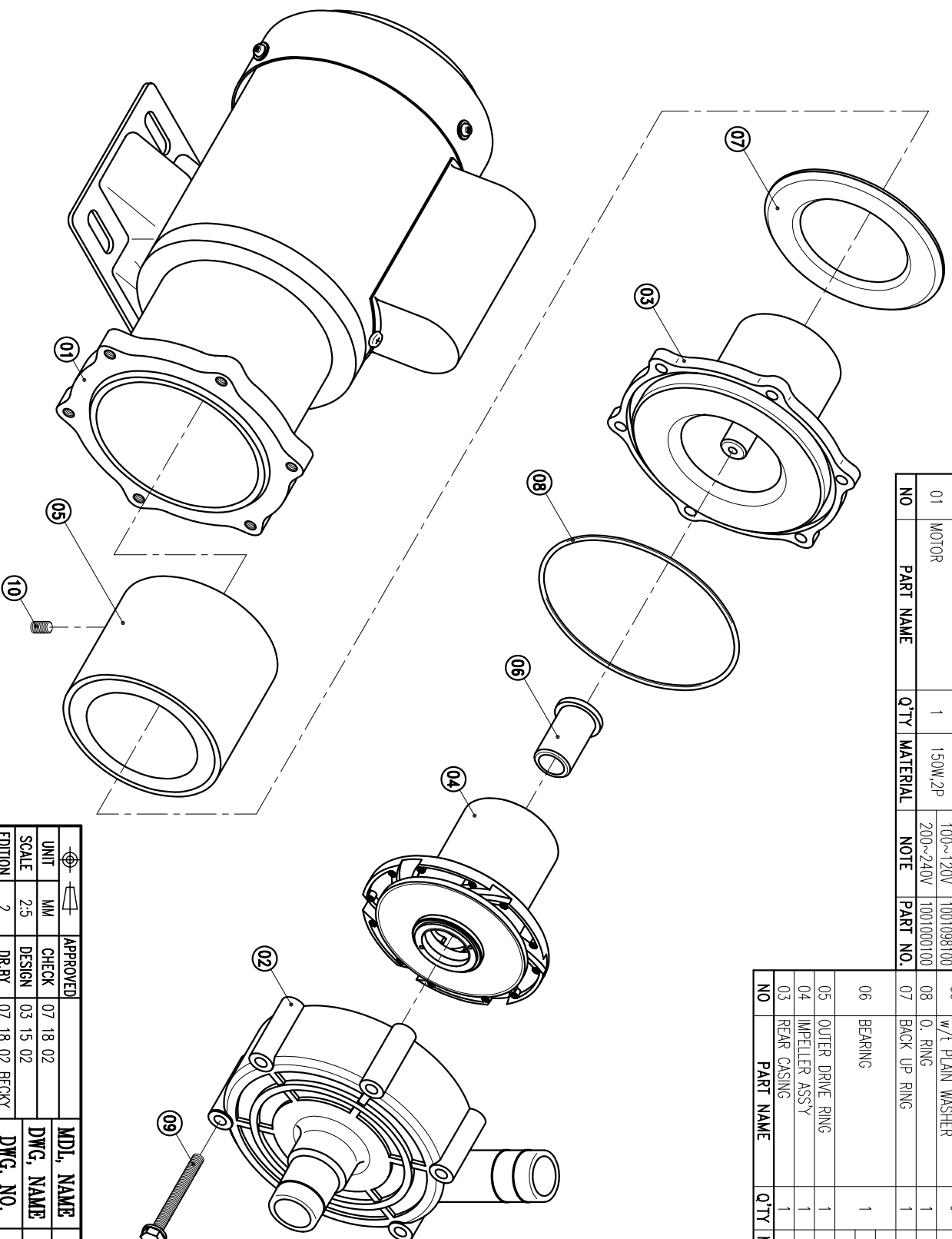

HOSE: 26mm X 26mm
G : 1" X 1"
NPT : 1" X 1"

UNIT	MM	CHECK	07 18 02	MDL NAME	NH-200PS-Z
SCALE	2.5	DESIGN	03 15 02	DWG. NAME	DECOMPOSITION DRAWING
EDITION	2	DR.BY	07 18 02 BECKY	DWG. NO.	B3202970
					A3

TPW
HONG YUAN



PAN WORLD CO., LTD.
パンワールド株式会社