

NO	PART NAME	QTY	MATERIAL	NOTE	PART NO.
02-1	FLANGE	2	PPG	25A	1001007100
02	FRONT CASING	1	PPG	φ123.5X87.5	1001006100
01	MOTOR	1	150W , 2P , 3φ		1001118301

11	SET SCREW	2	S435	M6X10	
10	HEXAGON HEAD BOLT w/t PLAIN WASHER	6	SUS304	M6X55	
09	O. RING	2	FKM	P20	1001301300
08	O. RING	1	FKM	G110	1001001300
07	BACK UP RING	1	SUS304	φ98X4.5	1001008600
06	BEARING	1	CERAMIC CARBON	φ25X35	1001000900
05	OUTER DRIVE RING	1	ADC-12	φ86X86	1003411800
04	IMPELLER ASS'Y	1	PPG		
03	REAR CASING	1	PPS	φ123.5X75	1001000500
NO	PART NAME	QTY	MATERIAL	NOTE	PART NO.

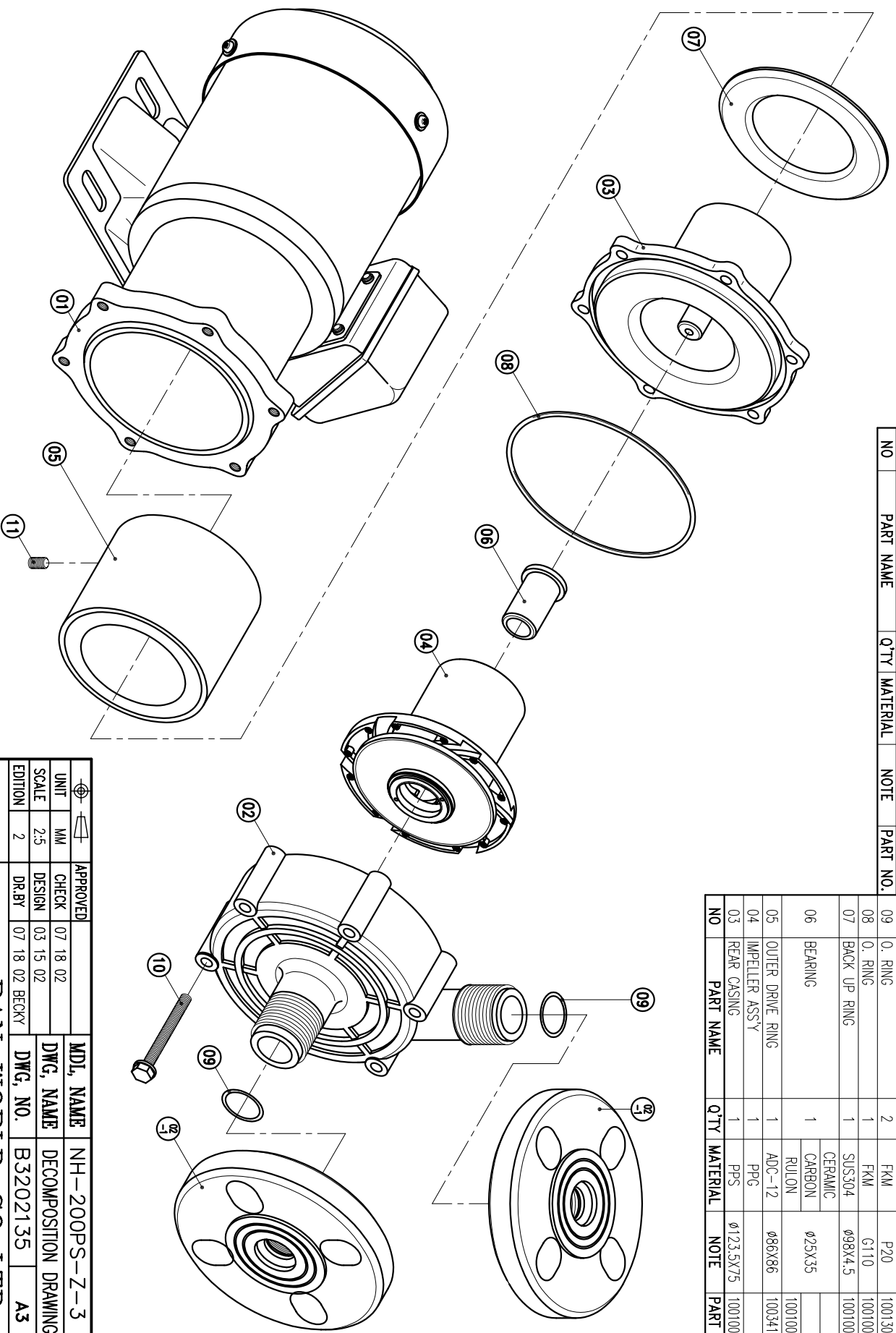

APPROVED	CHECK	DESIGN	DR.BY	MDL. NAME	DWG. NAME	DECOMPOSITION	DRAWING
	07 18 02	03 15 02	07 18 02 BECKY	NH-200PS-Z-3			
					DWG. NO.	B3202135	A3

TPW
HONG YUAN



PAN WORLD CO., LTD.
パンワールド株式会社