

NO	PART NAME	QTY	MATERIAL	NOTE	PART NO.
02-1	FLANGE	2	PPG	25A	1001007100
02	FRONT CASING	1	PPG	φ123.5X87.5	1001006100
01	MOTOR	1	90W, 2P	100~120V 200~240V	1001098099 1001000099

11	SET SCREW	2	S435	M6X10	
10	HEXAGON HEAD BOLT w/ t. PLAIN WASHER	6	SUS304	M6X55	
09	O. RING	2	FKM	P20	1001301300
08	O. RING	1	FKM	G110	1001001300
07	BACK UP RING	1	SUS304	φ98X4.5	1001008600
06	BEARING	1	CERAMIC CARBON RULON	φ25X35	1001000900
05	OUTER DRIVE RING	1	ADC-12	φ86X86	1003411800
04	IMPELLER ASS'Y	1	PPG		
03	REAR CASING	1	PPS	φ123.5X75	1001000500

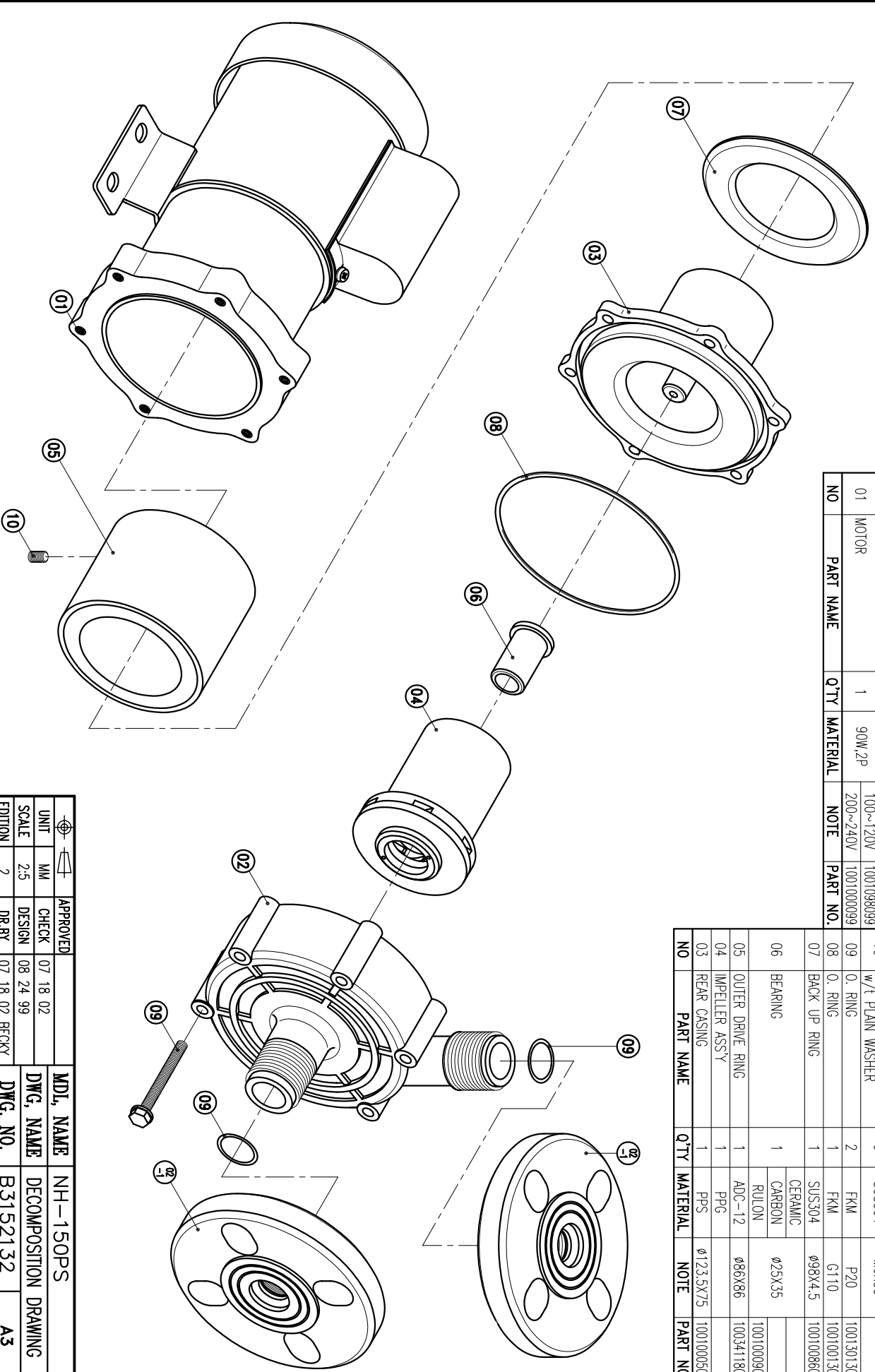

APPROVED	CHECK	07 18 02	MDL NAME	NH-150PS
UNIT	MM		DWG. NAME	DECOMPOSITION DRAWING
SCALE	2.5		DESIGN	08 24 99
EDITION	2		DR.BY	07 18 02 BECKY
			DWG. NO.	B3152132
				A3

TPW  
HONG YUAN



PAN WORLD CO., LTD.  
パンワールド株式会社