

03-3	O. RING	1	FKM	φ13.8xφ2.4	P14	05-2	OUTER MAGNET	1	FERRITE	φ80X30	P2522116	11	SET SCREW	2	S435	M6X10	P9116430
03-2	SPINDLE	1	CERAMIC	φ14X60	P2332110	05-1	MAGNET HOUSING	1	ADC-12	φ68X86	P2512114	10	HEXAGON HEAD BOLT w/L P.W (φ11.5xφ6.4X11.6)	6	SUS304	M6X55	P9119009
03-1	REAR THRUST PAD	1	CERAMIC	φ23X4	P2322109	05	OUTER DRIVE RING	1		φ66X86	P2509064						
03	REAR CASING	1	PPS	φ123.5X75	A2302131	04-4	IMPELLER COVER	1	PPG	φ100X20	P2452117	09	O. RING	2	FKM	φ19.8Xφ2.4	P20
02-2	FLANGE	2	PPG	25A	P2232756	04-3	INNER MAGNET	1	FERRITE	φ50X50	P2442113	08	O. RING	1	FKM	φ109.4Xφ3.1	G110
02-1	FRONT THRUST PAD	1	CERAMIC	φ40X7	P2222106	04-2	MOUTH RING	1	RUION	φ34X5	P2422112	07	BACK UP RING	1	SUS304	φ98X4.5	P2112067
02	FRONT CASING	1	PPG	φ123.5X87.5	P2202061	04-1	IMPELLER VANE	1	PPG	φ100X76.5	P2412111						
01	MOTOR	1	250W , 2P	100~120V,200~240V		04	IMPELLER ASS'Y	1	PPG		P2402063	06	BEARING	1	CERAMIC CARBON RUION	φ25X35	P2462065
NO	PART NAME	Q'TY	MATERIAL	NOTE	DWG. NO.	NO	PART NAME	Q'TY	MATERIAL	NOTE	DWG. NO.	NO	PART NAME	Q'TY	MATERIAL	NOTE	DWG. NO.

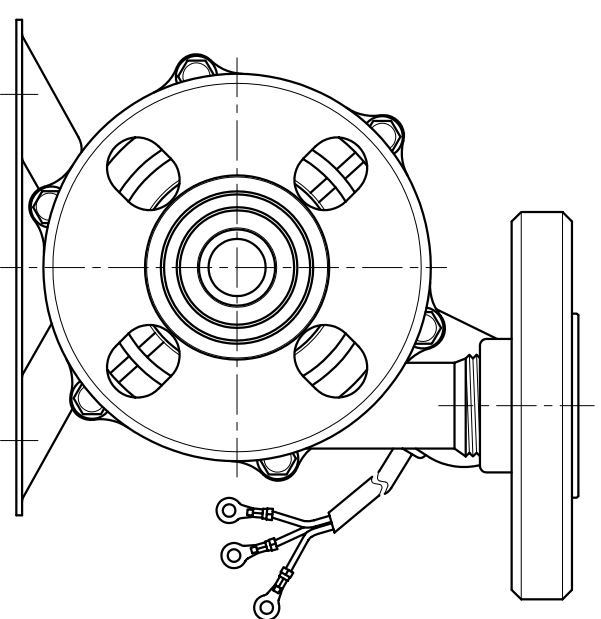

APPROVED	MDL NAME	NH-250PS
CHECK	DWG. NAME	CONSTRUCTION DRAWING
DESIGN	DWG. NO.	B2252488
DR.BY		A3
EDITION		
2		

TPW
HONG YUAN

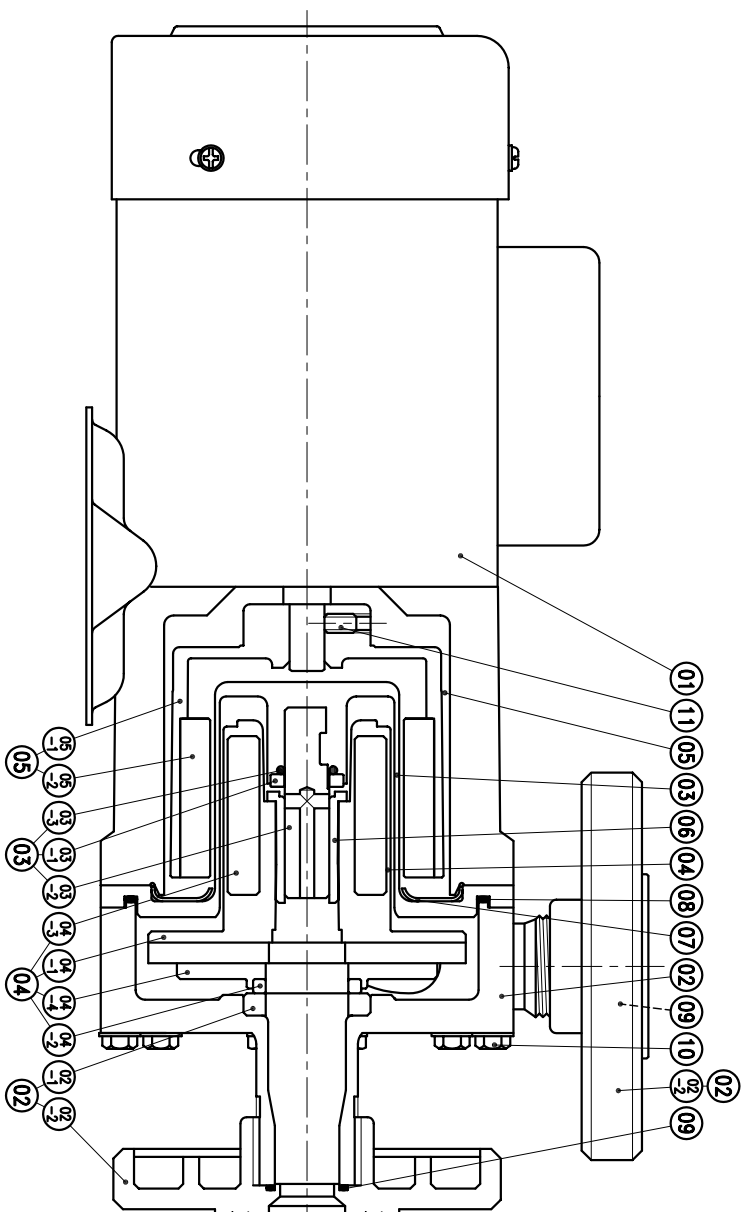

PAN WORLD CO., LTD.
パンワールド株式会社