

03-3	O. RING	1	FKM	φ13.8Xφ2.4	P14	05-1	MAGNET HOUSING	1	ADC-12	φ68X86	P2512114	10	SET SCREW	2	S435	M6X10	P9116430	
03-2	SPINDLE	1	CERAMIC	φ14X60	P2332110	05	OUTER DRIVE RING	1	PPG	φ68X86	P2509064	09	HEXAGON HEAD BOLT w/L P.W.(φ11.5Xφ6.4X11.6)	6	SUS304	M6X55	P9113079	
03-1	REAR THRUST PAD	1	CERAMIC	φ23X4	P2332109	04-4	IMPELLER COVER	1	PPG	φ100X20	P2452117	08	O. RING	1	FKM	φ109.4Xφ3.1	G110	
03	REAR CASING	1	PPS	φ123.5X75	A2302131	04-3	INNER MAGNET	1	FERRITE	φ50X50	P2442113	07	BACK UP RING	1	SUS304	φ98X4.5	P2112067	
02-1	FRONT THRUST PAD	1	CERAMIC	φ40X7	P2222106	04-2	MOUTH RING	1	ROLON	φ34X5	P2422112	06	BEARING	1	CERAMIC CARBON	φ25X35	P2462956 P2462217 P2462065	
02	FRONT CASING	1	PPG	φ123.5X87.5	P2202061	04-1	IMPELLER VANE	1	PPG	φ100X76.5	P2412111							
01	MOTOR	1	150W , 2P 3φ 200/400V,220/380V			04	IMPELLER ASS'Y	1	PPG		P2402063							
NO	PART NAME	Q'TY	MATERIAL	NOTE	DWG. NO.	NO	PART NAME	Q'TY	MATERIAL	NOTE	DWG. NO.	NO	PART NAME	Q'TY	MATERIAL	NOTE	DWG. NO.	
						05-2	OUTER MAGNET	1	FERRITE	φ80X50	P2522116							

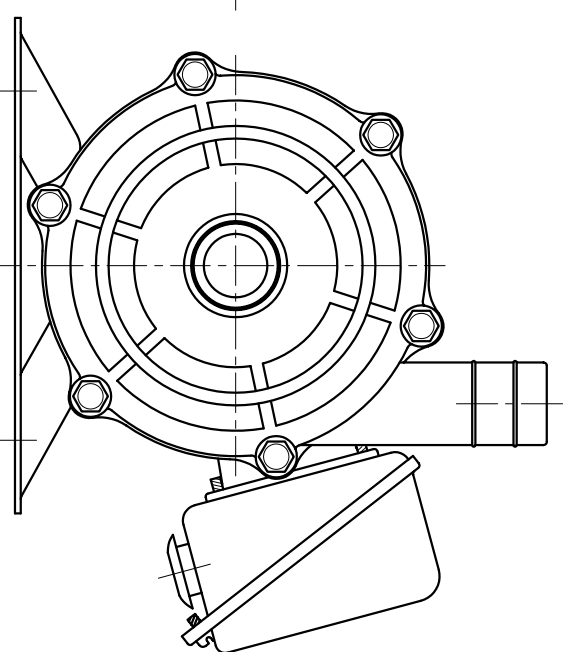
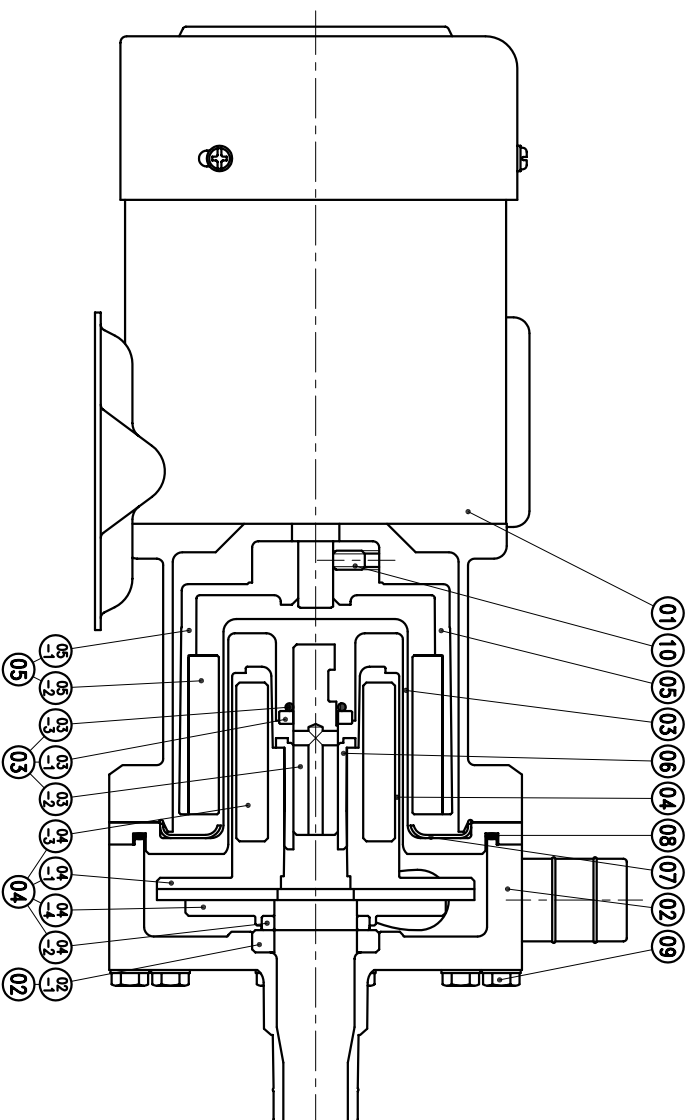

G : 1"X 1"
NPT : 1"X 1"

APPROVED		MDL NAME	NH-200PS-Z-3
CHECK	07 17 02	DWG. NAME	CONSTRUCTION DRAWING
DESIGN	10 12 98	DWG. NO.	B2202404
DR.BY	07 17 02 BECKY		A3

TPW
HONG YUAN



PAN WORLD CO.,LTD.
パンワールド株式会社