

NO	PART NAME	Q'TY	MATERIAL	NOTE	DWG. NO.	NO	PART NAME	Q'TY	MATERIAL	NOTE	DWG. NO.
03-3	O. RING	1	FKM	φ13.8xφ2.4	P14	05-2	OUTER MAGNET	1	FERRITE	φ80X30	P2522116
03-2	SPINDLE	1	CERAMIC	φ14x60	P2332110	06-1	MAGNET HOUSING	1	ADC-12	φ68X86	P2512114
03-1	REAR THRUST PAD	1	CERAMIC	φ23x4	P2322109	05	OUTER DRIVE RING	1		φ66X86	P2509064
03	REAR CASING	1	PPS	φ123.5x75	A2302131	04-4	IMPELLER COVER	1	PPG	φ100X20	P2452117
02-2	FLANGE	2	PPG	25A	P2232756	04-3	INNER MAGNET	1	FERRITE	φ50X50	P2442113
02-1	FRONT THRUST PAD	1	CERAMIC	φ40x7	P2222106	04-2	MOUTH RING	1	RUION	φ34x5	P2422112
02	FRONT CASING	1	PPG	φ123.5x87.5	P2202061	04-1	IMPELLER VANE	1	PPG	φ100X76.5	P2412111
01	MOTOR	1	150W , 2P 3φ 200/400V,220/380V			04	IMPELLER ASS'Y	1	PPG		P2402063
						11	SET SCREW	2	S435	M6X10	P9116430
						10	HEXAGON HEAD BOLT w/L P.W (φ11.5xφ6.4X11.6)	6	SUS304	M6X55	P9119009
						09	O. RING	2	FKM	φ19.8xφ2.4	P20
						08	O. RING	1	FKM	φ109.4xφ3.1	G110
						07	BACK UP RING	1	SUS304	φ98X4.5	P2112067
						06	BEARING	1	CERAMIC CARBON RUION	φ25X35	P2462956 A246217 P2462065

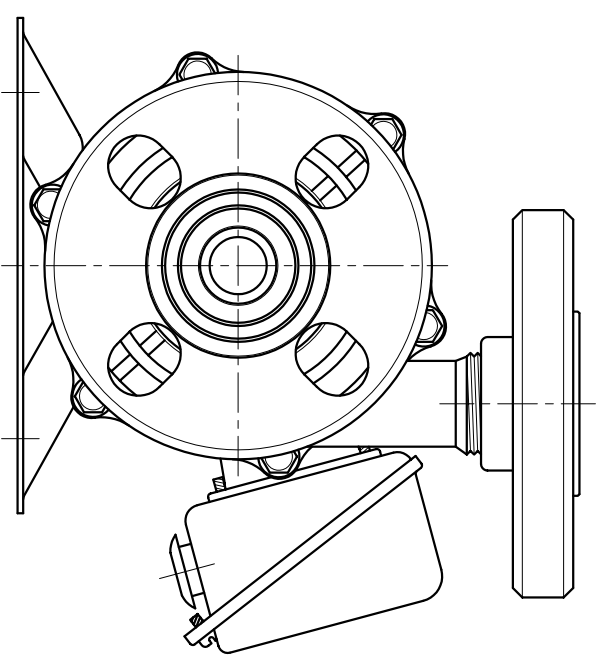
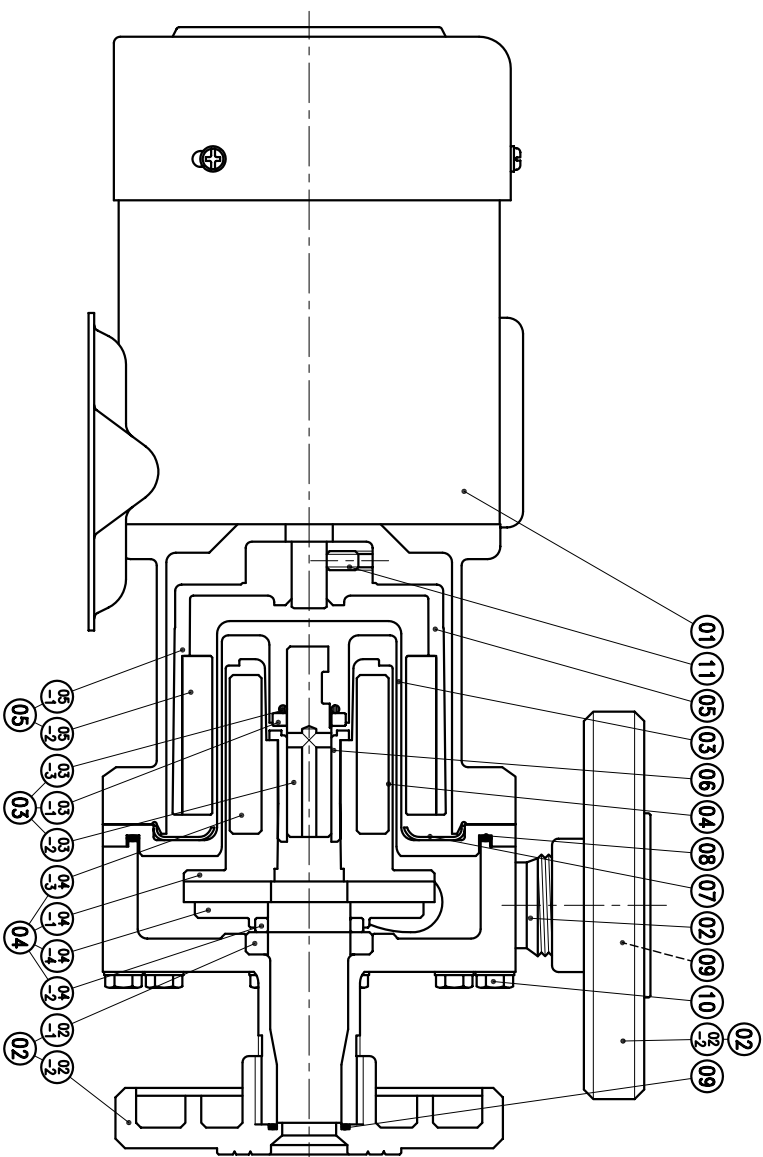

APPROVED	MDL NAME	NH-200PS-3
CHECK	DWG. NAME	CONSTRUCTION DRAWING
DESIGN	DWG. NO.	B2202193
DR.BY		A3
EDITION		

 TPW
 HONG YUAN
 PAN WORLD CO.,LTD.
 パンワールド株式会社