

NO	PART NAME	Q'TY	MATERIAL	NOTE	PART NO.
01	MOTOR	1	350W, 2P		
02	FRONT CASING	1	ETFE CERAMIC	THREAD HOSE	
03	REAR CASING	1	ETFE		
04	IMPELLER ASS'Y	1	ETFE	SIC	
05	OUTER DRIVE RING	1	ADC-12	φ117.5X119	100301800
06	BEARING ASS'Y	1			
07	INNER DRIVE RING	1	ETFE	φ79.6X71	1004510814
08	BACK UP RING	1	SUS304	φ140X5.5	1004510813
09	O. RING	1	FKM	G130	1004510812
10	HEXAGON HEAD BOLT w/t PLAIN WASHER	1	SUS304	M8X50	1004510811
11	SET SCREW	2	S435	M8X10	

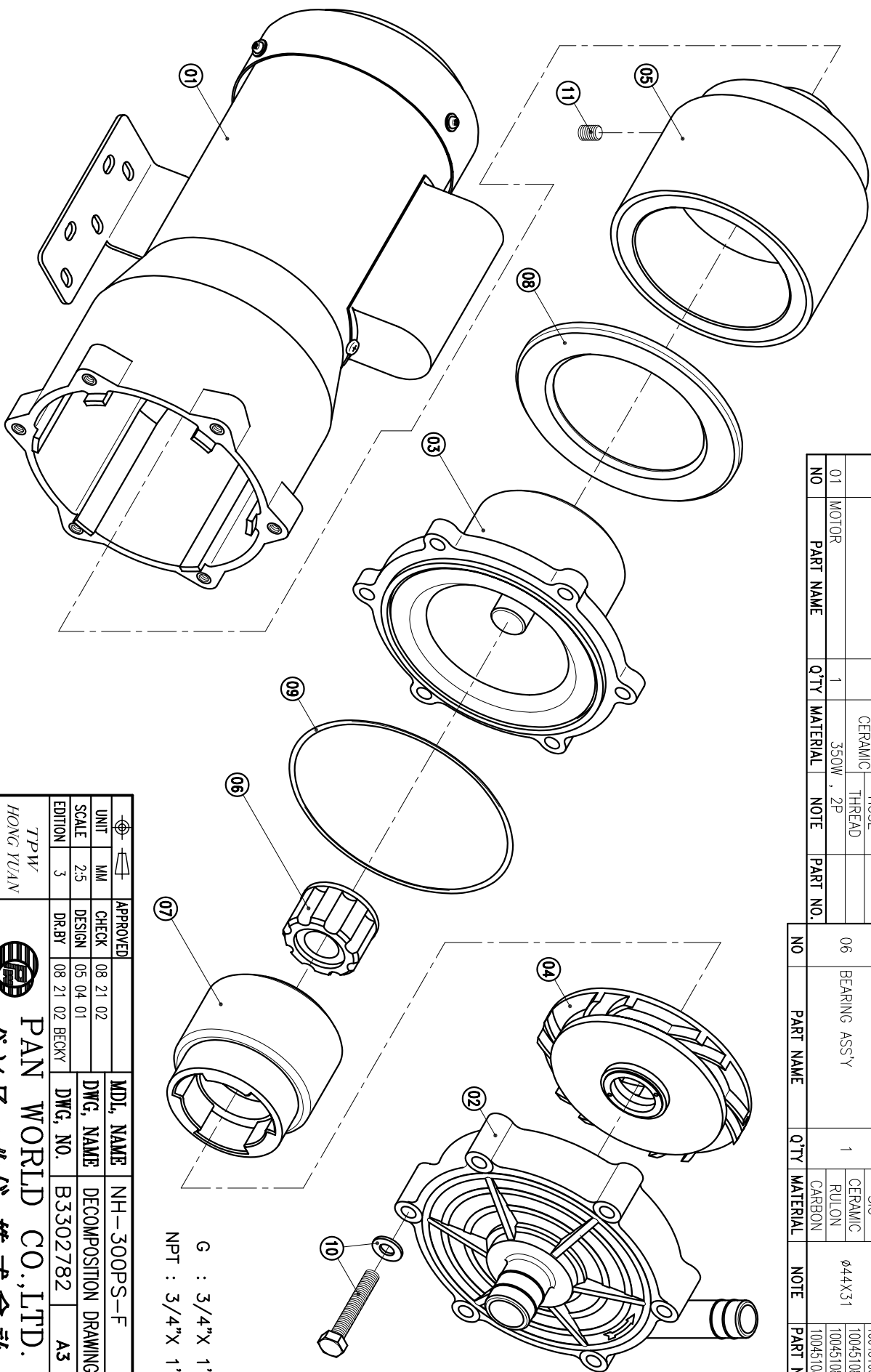

G : 3/4" X 1"
NPT : 3/4" X 1"

APPROVED	CHECK	08 21 02	MDL NAME	NH-300PS-F
SCALE	DESIGN	05 04 01	DWG. NAME	DECOMPOSITION DRAWING
EDITION	DR.BY	08 21 02 BECKY	DWG. NO.	B3302782
				A3

TPW
HONG YUAN

PAN WORLD CO., LTD.
パンワールド株式会社