

NO	PART NAME	QTY	MATERIAL	NOTE	PART NO.
02-1	FLANGE	2	ETFE	25A	1002928100
02	FRONT CASING	1	ETFE	SIC	1002928190
				CERAMIC	1002928100
01	MOTOR	1	150W, 2P, 3φ		1001118301
11	SET SCREW	2	S435		6x10
10	HEXAGON HEAD BOLT w/PLAIN WASHER	6	SUS304	6x55	
09	O. RING	2	FKM	P20	
08	O. RING	1	FKM	G110	1002921100
07	BACK UP RING	1	SUS304	φ98x4.5	1001009800
			SIC		1031000900
06	BEARING	1	CERAMIC CARBON RULON	φ25x35	
05	OUTER DRIVE RING	1	ADC-12	φ86x86	1001000900 1003411800
04	IMPELLER ASS'Y	1	ETFE		
03	REAR CASING	1	ETFE	SIC	1010000900
				CERAMIC	1040000900

NO	PART NAME	QTY	MATERIAL	NOTE	PART NO.
02	FRONT CASING	1	ETFE		
01	MOTOR	1	150W, 2P, 3φ		
11	SET SCREW	2	S435		6x10
10	HEXAGON HEAD BOLT w/PLAIN WASHER	6	SUS304	6x55	
09	O. RING	2	FKM	P20	
08	O. RING	1	FKM	G110	1002921100
07	BACK UP RING	1	SUS304	φ98x4.5	1001009800
			SIC		1031000900
06	BEARING	1	CERAMIC CARBON RULON	φ25x35	
05	OUTER DRIVE RING	1	ADC-12	φ86x86	1001000900 1003411800
04	IMPELLER ASS'Y	1	ETFE		
03	REAR CASING	1	ETFE	SIC	1010000900
				CERAMIC	1040000900

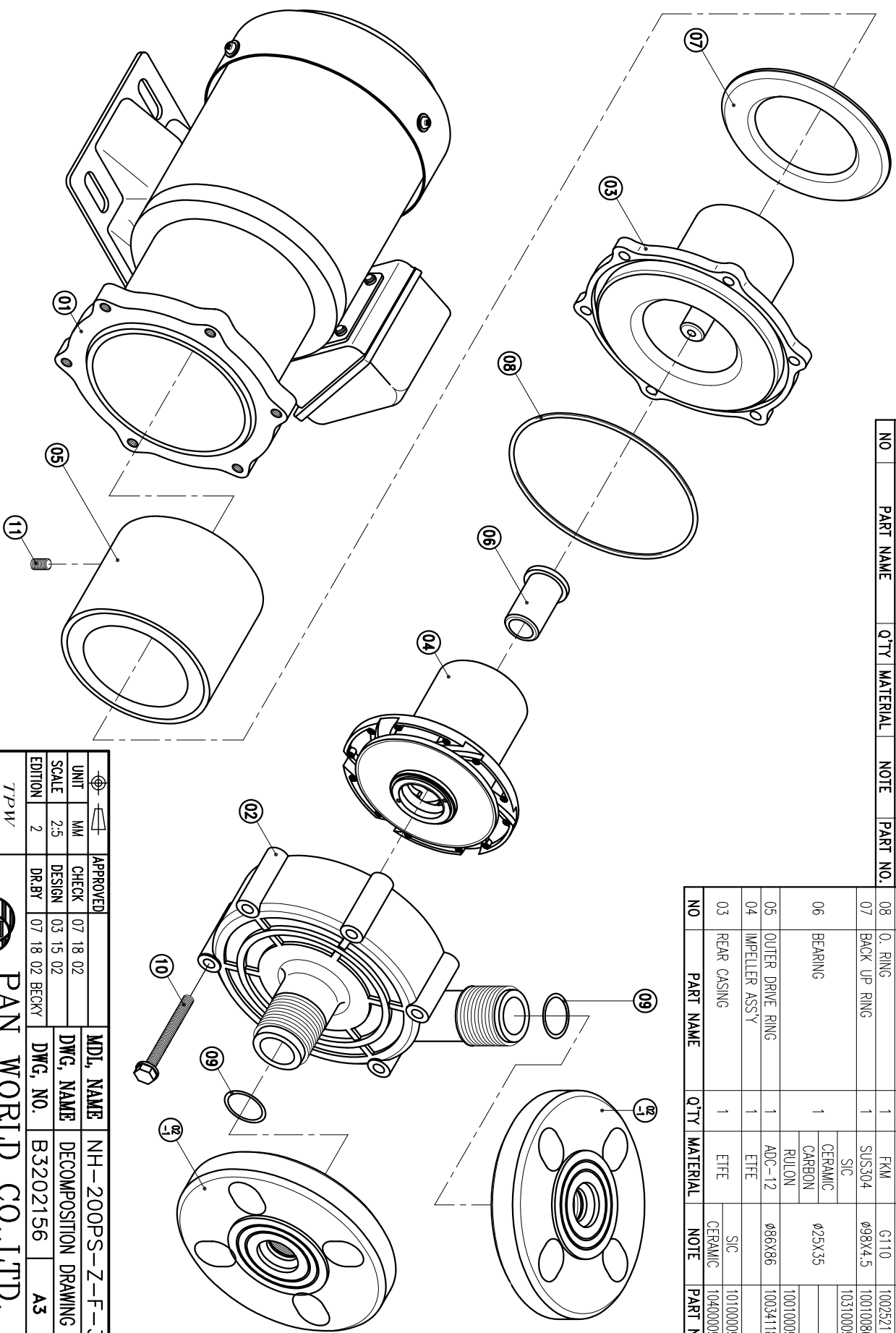

APPROVED	CHECK	07 18 02	MDL NAME	NH-200PS-Z-F-3
			DWG. NAME	DECOMPOSITION DRAWING
			DWG. NO.	B3202156
			DR.BY	07 18 02 BECKY
			EDITION	2
			SCALE	2.5
			UNIT	MM

TPW  
HONG YUAN

**PAN WORLD CO., LTD.**  
PANワールド株式会社