

NO	PART NAME	Q'TY	MATERIAL	NOTE	PART NO.
02	FRONT CASING	1	ETFE CERAMIC	HOSE THREAD HOSE 1002526190 1002526100	
01	MOTOR	1	150W, 2P, 3ø	100118301	

10	SET SCREW	2	S435	M6X10	
09	HEXAGON HEAD BOLT w/t PLAIN WASHER	6	SUS304	M6X55	
08	O. RING	1	FKM	G110	10025271100
07	BACK UP RING	1	SUS304	ø98X4.5	10010086800
			SIC		10310009900
06	BEARING	1	CERAMIC CARBON	ø25X35	
			RIULON		10010009900
05	OUTER DRIVE RING	1	ADC-12	ø66X86	1003411800
04	IMPELLER ASS'Y	1	ETFE		
03	REAR CASING	1	ETFE		
			SIC		10100009900
			CERAMIC		10400009900

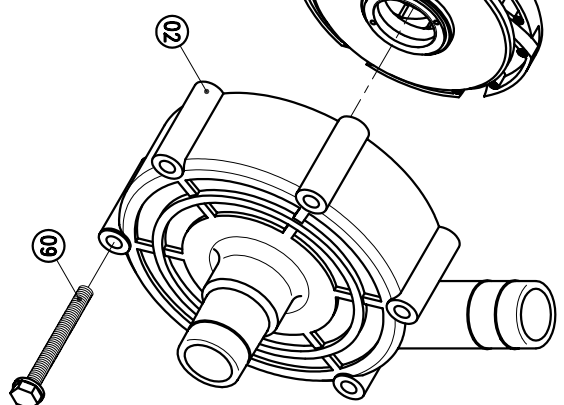
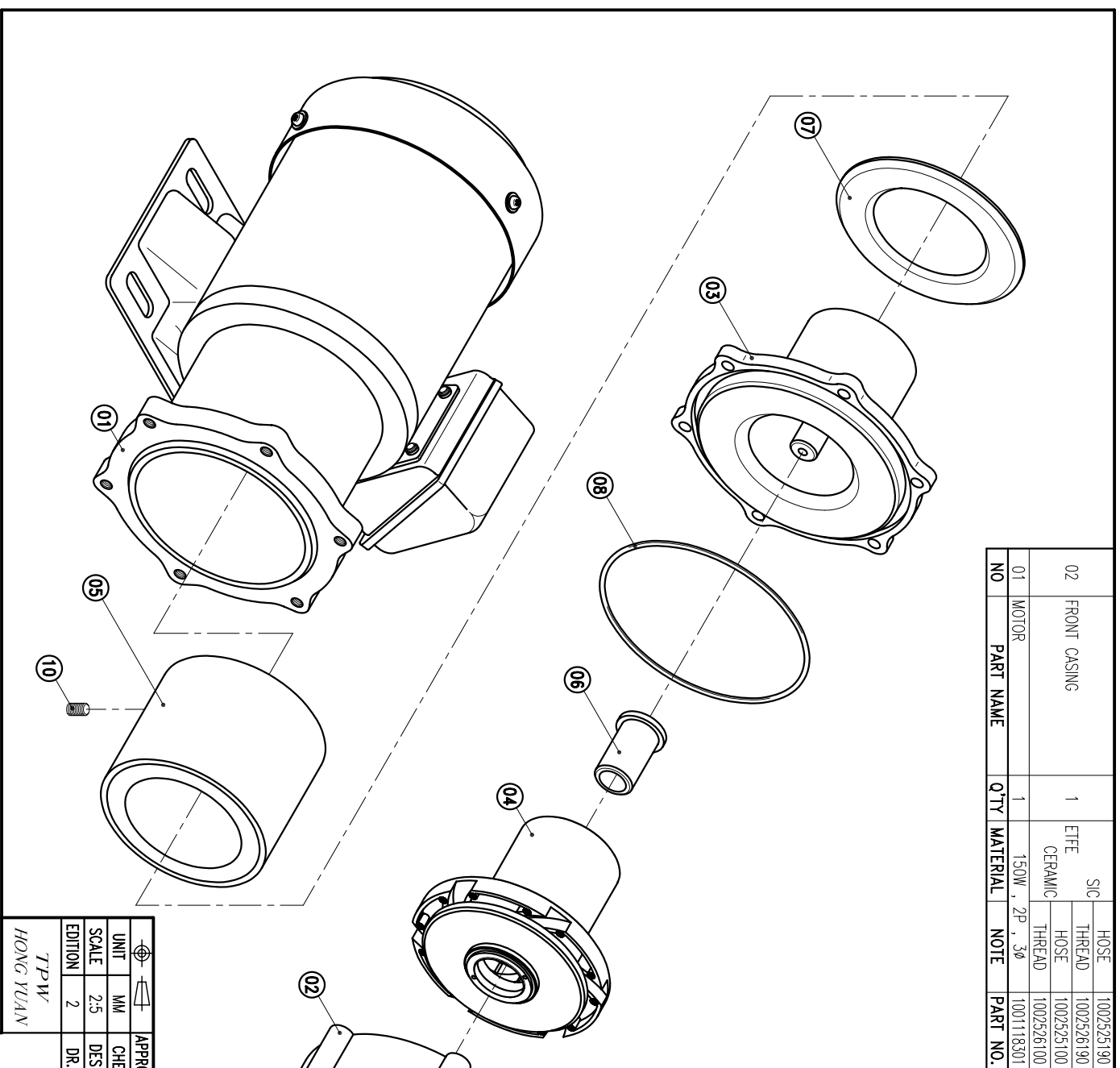

HOSE: 26mm X 26mm
 G : 1" X 1"
 NPT : 1" X 1"

APPROVED	CHECK	07 18 02	MDL NAME	NH-200PS-F-3
UNIT	MM		DWG. NAME	DECOMPOSITION DRAWING
SCALE	2.5		DWG. NO.	B3202155
EDITION	2		DR.BY	07 18 02 BECKY
				A3

TPW
HONG YUAN

PAN WORLD CO., LTD.
 パンワールド株式会社