

NO	PART NAME	Q'TY	MATERIAL	NOTE	PART NO.
02	FRONT CASING	1	ETFE CERAMIC	HOSE THREAD HOSE 1002525190 1002525100	
01	MOTOR	1	90W, 2P	200~240V 1001098099 1001000099	

10	SET SCREW	2	S435	M6X10	
09	HEXAGON HEAD BOLT w/PLAIN WASHER	6	SUS304	M6X55	
08	O. RING	1	FKM	G110	1002521100
07	BACK UP RING	1	SUS304	φ98X4.5	1001008600
			SIC		1031000900
06	BEARING	1	CERAMIC CARBON RULON	φ25X35	
05	OUTER DRIVE RING	1	ADC-12	φ86X86	1001000900 1003411800
04	IMPELLER ASS'Y	1	ETFE		
03	REAR CASING	1	ETFE		
			SIC		1010000900
			CERAMIC		1040000900

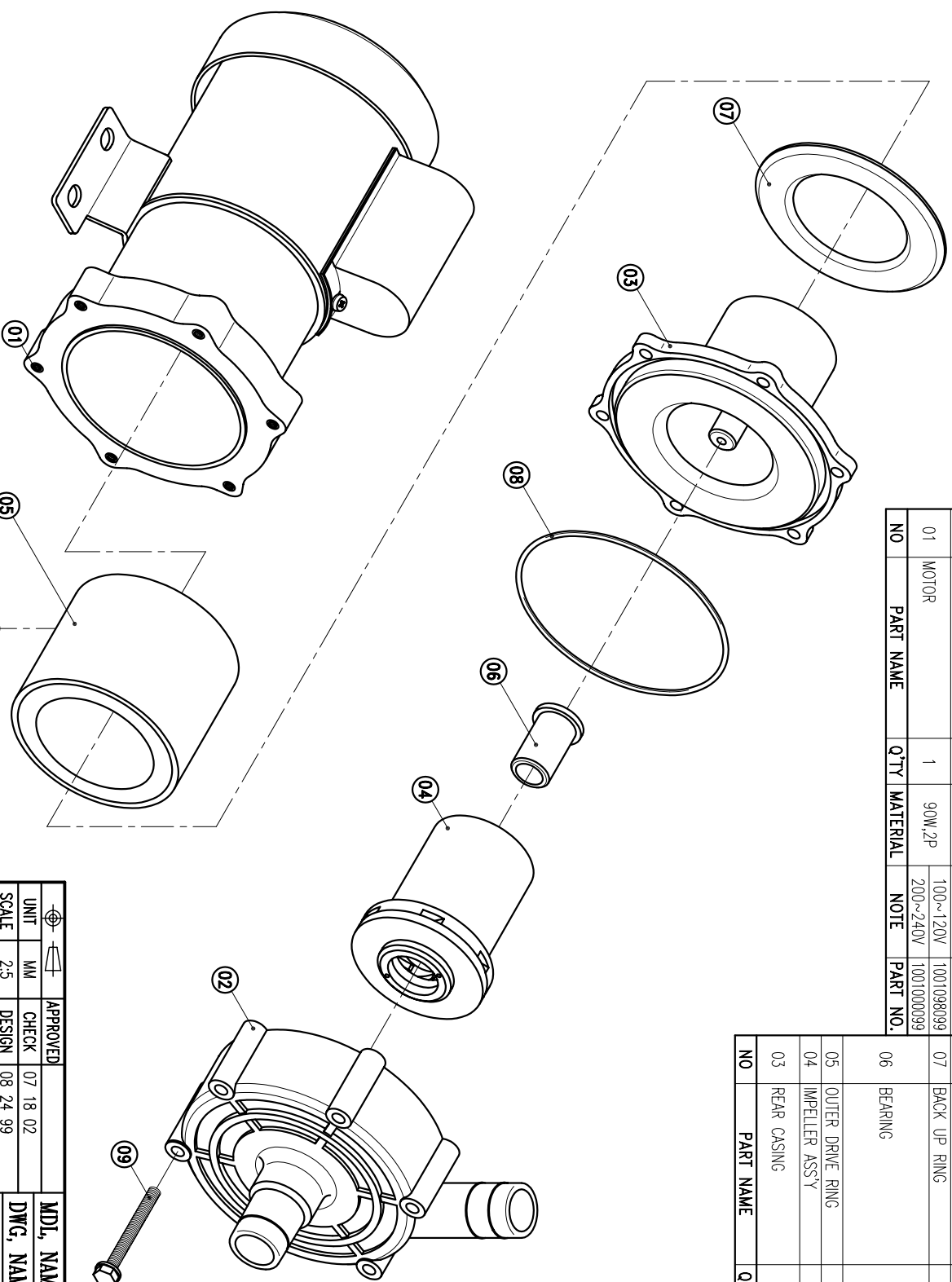

HOSE: 26mm X 26mm  
G : 1" X 1"  
NPT : 1" X 1"

APPROVED	CHECK	07 18 02	MDL NAME	NH-150PS-F
TPW	MM	07 18 02	DWG. NAME	DECOMPOSITION DRAWING
HONG YUAN	SCALE	08 24 99	DWG. NO.	B3152922
	EDITION	07 18 02 BECKY		A3

**PAN WORLD CO., LTD.**  
**パンワールド株式会社**