

NO	PART NAME	Q'TY	MATERIAL	NOTE	DWG. NO.	NO	PART NAME	Q'TY	MATERIAL	NOTE	DWG. NO.						
03-2	REAR THRUST PAD	1	SIC	φ23X4	P2322109	05	OUTER DRIVE RING	1	φ68X86	P2509064	11	SET SCREW	2	S435	M6X10	P9116430	
03-1	SPINDLE HOLDER	1	CERAMIC			04-4	IMPELLER COVER	1	ETFE	φ100X20	P2452117	10	HEXAGON HEAD BOLT	6	SUS304	M6X55	P9119009
03	REAR CASING	1	ETFE	φ25X64	A2372356	04-3	INNER MAGNET	1	FERRITE	φ50X50	P2442113	09	W/L P.W (φ11.5Xφ6.4X1.6)	2	FKM	φ19.8Xφ2.4	P20
02-2	FLANGE	2	ETFE	φ123.5X74	P2302062	04-2	MOUTH RING	1	RUOLON	φ34X5	P2422112	08	O. RING	1	FKM	φ109.4Xφ3.1	G110
02-1	FRONT THRUST PAD	1	SIC	25A	P2232756	04-1	IMPELLER VANE	1	ETFE	φ100X76.5	P2412111	07	BACK UP RING	1	SUS304	φ98X4.5	P2112067
02	FRONT CASING	1	CERAMIC	φ40X7	P2222106	04	IMPELLER ASS'Y	1	TEFLON	φ13.8Xφ2.4	P14	06	BEARING	1	SIC	φ25X35	P246637
01	MOTOR	1	ETFE	φ123.5X87.5	P2202061	03-4	O. RING	1	SIC	φ14X60	P2332110	05-2	OUTER MAGNET	1	CERAMIC	φ25X35	P246637
						03-3	SPINDLE	1	CERAMIC			05-1	MAGNET HOUSING	1	ADC-12	φ80X50	P2522116

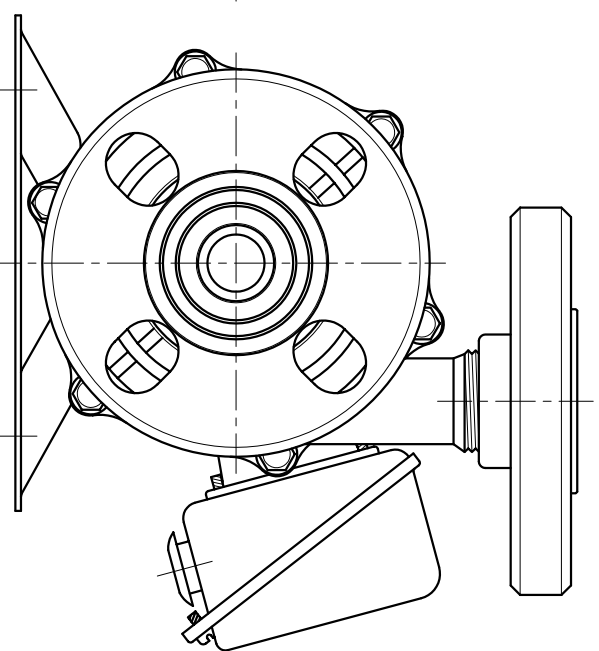

APPROVED		MDL NAME	NH-250PS-F-3
CHECK	07 18 02	DWG. NAME	CONSTRUCTION DRAWING
DESIGN	10 09 98	DWG. NO.	B2252491
DR.BY	07 18 02 BECKY		A3

TPW
HONG YUAN

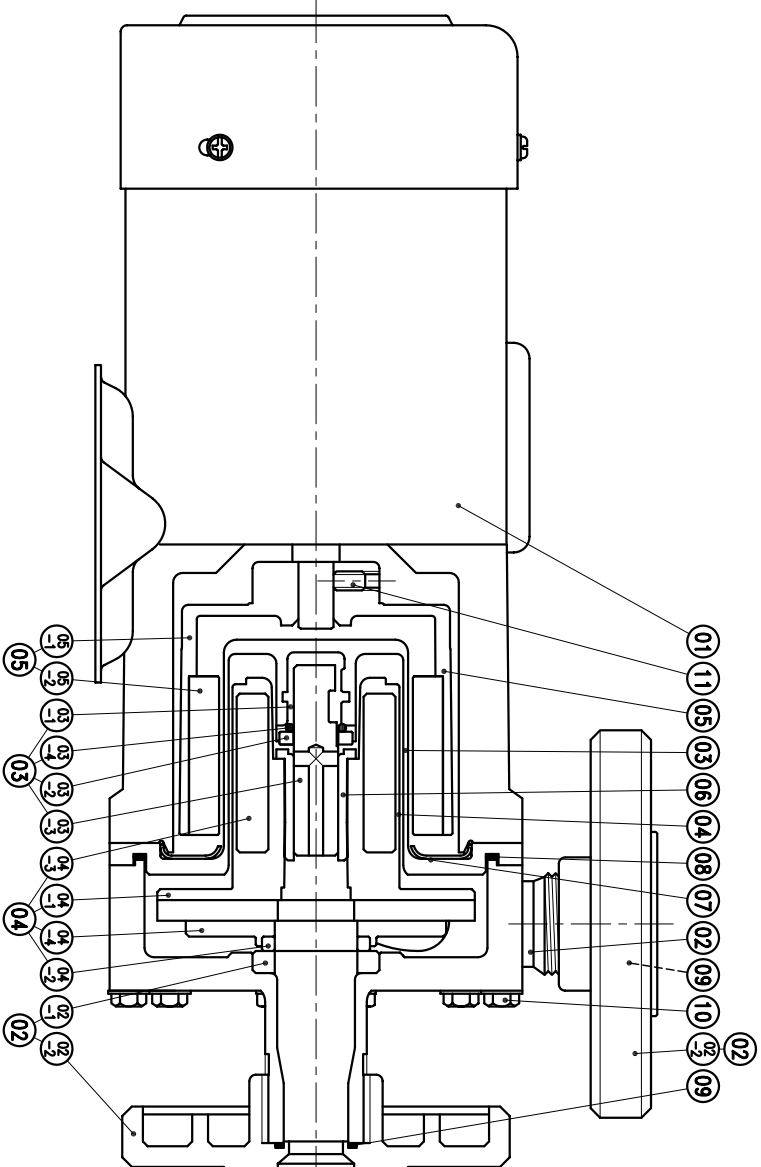

PAN WORLD CO., LTD.
パンワールド株式会社