

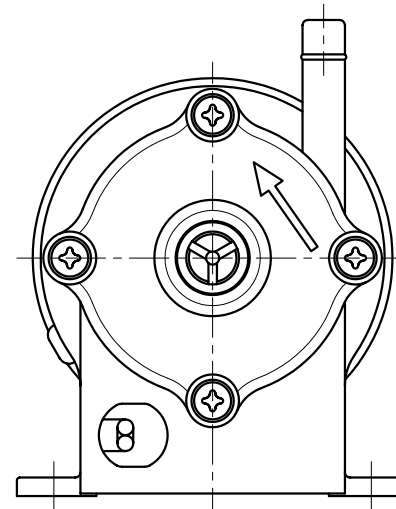

03-1	SPINDLE	1	CERAMIC	φ4X27	A2331603	05	OUTER DRIVE RING	1		φ41X26	P2501199	08	SET SCREW	2	S435	M3X4	
03	REAR CASING	1	PPG	φ54X20.5	P2301036	04-4	THRUST PAD	1	RULON	φ12X2.5	A2321604	07	SCREW,CROSS RECESS HEAD w/t P.W.(φ8Xφ4.3Xt0.8)	4	SUS304	M4X25	
02-1	FRONT THRUST PAD	1	CERAMIC	φ10Xφ4X2	A2221602	04-3	IMPELLER COVER	1	PPG	φ43X1.5	P2451213						
02	FRONT CASING	1	PPO	φ54X33.5	A2211598	04-2	INNER MAGNET	1	FERRITE	φ18X12	P2441115	06	O. RING	1	FKM	φ44.5Xφ2	S45
01	MOTOR	BRUSHLESS , 8W , DC12V , DC24V				04-1	IMPELLER VANE	1	PPG	φ43X21	A2411610	05-2	OUTER MAGNET	1	FERRITE	φ38Xφ25X10	P2521094
NO	PART NAME	Q'TY	MATERIAL	NOTE	DWG. NO.	04	IMPELLER ASS'Y	1	PPG	φ43X22.5	A2401609	05-1	MAGNET HOUSING	1	ADC-12	φ41Xφ5X21	P2511004
NO	PART NAME	Q'TY	MATERIAL	NOTE	DWG. NO.	NO	PART NAME	Q'TY	MATERIAL	NOTE	DWG. NO.	NO	PART NAME	Q'TY	MATERIAL	NOTE	DWG. NO.

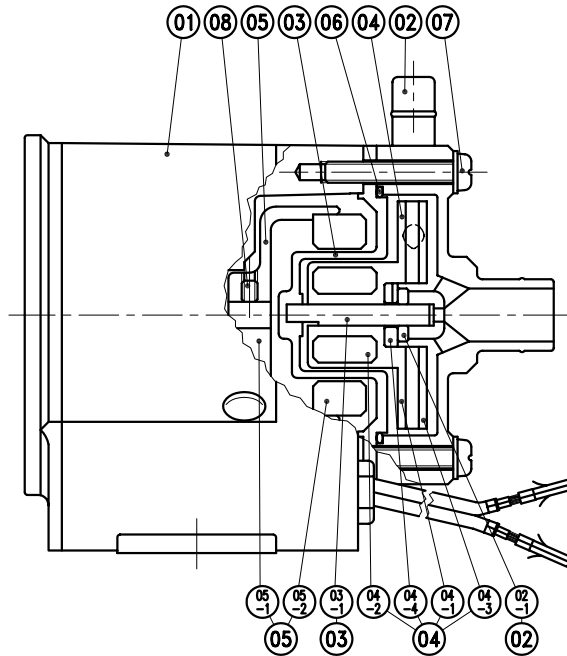

APPROVED		MDL. NAME	NH-5PI-Z-D	
UNIT	MM	CHECK	07 26 04	
SCALE	1:1	DESIGN	10 14 03	
EDITION	1	DR.BY	07 26 04 BECKY	DWG. NO. E2001383
TPW HONG YUAN		 PAN WORLD CO.,LTD. パンワールド 株式会社		