

02-2	FLANGE	1	PPG	50A	
02-1	FLANGE	1	PPG	65A	
02	FRONT CASING	1	THRUST PAD: CERAMIC BEARING: CARBON THRUST PAD: SIC BEARING: SIC		
01	BRACKET	1	FC-20	φ226.5X205	

08	REAR CASING COVER	1		φ158X121	
07	SPINDLE	1	CERAMIC SIC	φ38X156	
06	MAGNET CAPSULE	1	PPG	φ79.6X92	
05-2	RING	1	S45C	φ65X5.7	
05-1	FLY WHEEL	1	S45C	φ122X68	
05	DRIVE MAGNET	1	FCD-45	φ122X199	
04	IMPELLER ASS'Y	1	PPS	5012PH 5013PH CARBON SIC	
03	REAR CASING	1	PPS		

16	HEXAGON SOCKET BOLT	4	SUS304	1/2"-13X1 1/4"	
15	HEXAGON SOCKET BOLT w/1 SPRING WASHER	4	SUS304	M8X60	
14	EYE BOLT	1	S41C	M12X20	
13	SET SCREW	2	S435	M8X10	
12	HEXAGON HEAD BOLT w/1 SPRING WASHER w/1 PLAN WASHER	8	SUS304	M10X80	
11	O. RING	1	FKM	S50	
10	O. RING	1	FKM	S65	
09	O. RING	1	FKM	G200	

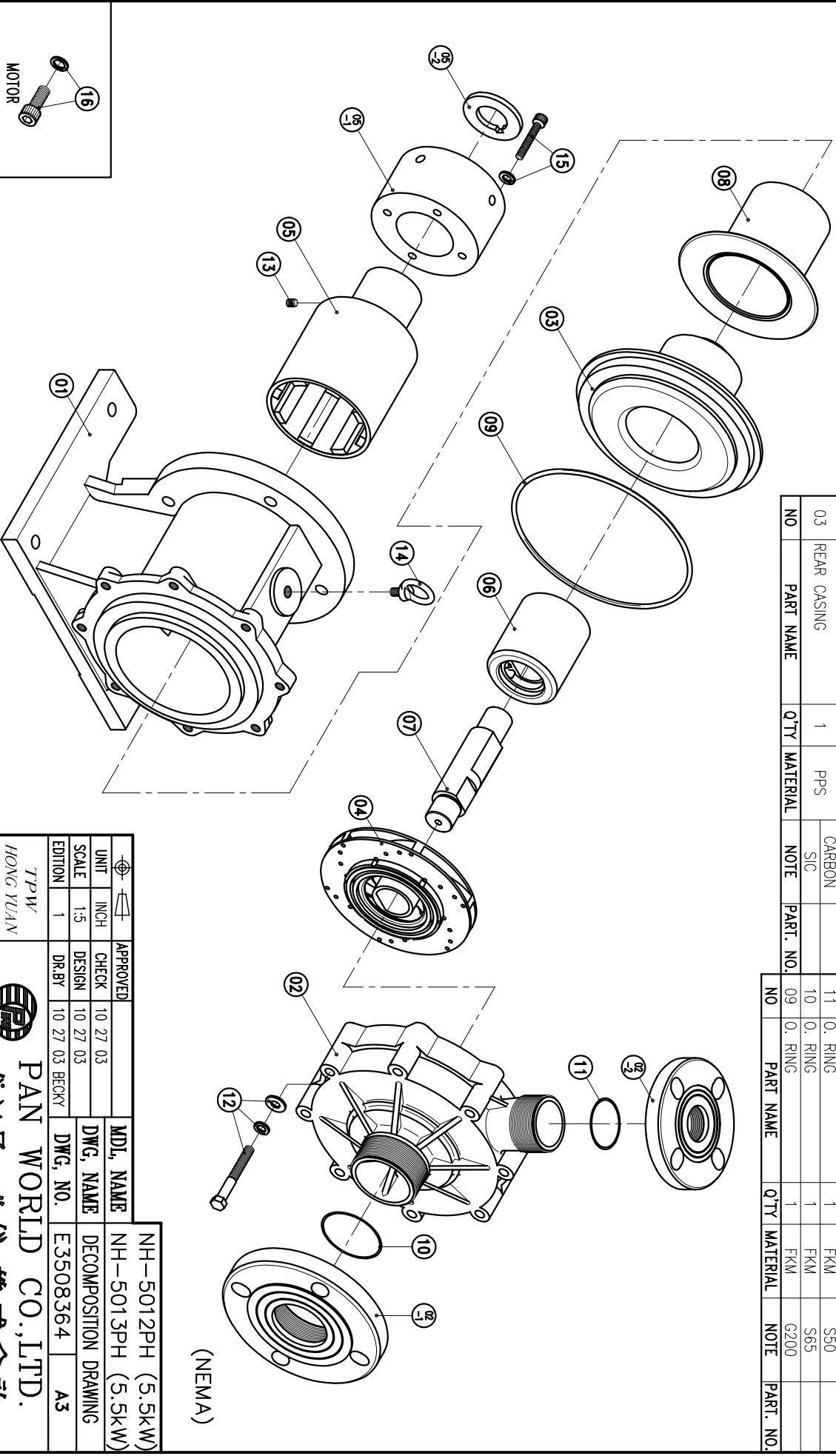

(NEMA)

APPROVED	CHECK	10 27 03	MDL NAME	NH-5012PH (5.5kW)
DESIGN	10 27 03		DWG. NAME	NH-5013PH (5.5kW)
DR.BY	10 27 03	BECKY	DECOMPOSITION DRAWING	
EDITION	1		DWG. NO.	E3508364
				A3

TPW
HONG YUAN



PAN WORLD CO., LTD.
パンワールド株式会社