

02-1	FLANGE	1	PPG	50A					
02-B	CASING-2ND	1	PPS	φ226.5X59.5					
02-1	FLANGE	1	PPG	65A					
02-A	FRONT CASING-1ST	1	PPS	THRUST PAD: CERAMIC BEARING: CARBON					
01-1	TRANSITION FLANGE	1	FC-20	φ254X21.6					
01	BRACKET	1	FC-20	φ226.5X205					

10	O. RING	1	FKM	S65					
09	O. RING	1	FKM	G200					
08	REAR CASING COVER	1		φ158X121					
07	SPINDLE	1	CERAMIC	φ38X198					
06	MAGNET CAPSULE	1	PPG	φ79.6X92					
05-1	FLY WHEEL	1	S45C	φ122X97					
05	DRIVE MAGNET	1	FCD-45	φ122X199					
04	IMPELLER ASS'Y	1	PPS	5013PH CARBON					
03	REAR CASING	1	PPS	SIC					
17	HEXAGON SOCKET BOLT	4	SUS304	1/2"-13x1 1/4"					
16	HEXAGON SOCKET WASHER	4	SUS304	M12X25					
15	HEXAGON SOCKET BOLT	4	SUS304	M8X90					
14	HEXAGON SOCKET WASHER	4	SUS304	M8X90					
13	W/1 SPRING WASHER	1	S41C	M12X20					
12	SET SCREW	2	S435	M8X10					
11	HEXAGON HEAD BOLT	1	S41C	M12X20					
10	W/1 SPRING WASHER	8	SUS304	M10X120					
11	W/1 PLAIN WASHER	8	SUS304	M10X120					
11	O. RING	1	FKM	S50					

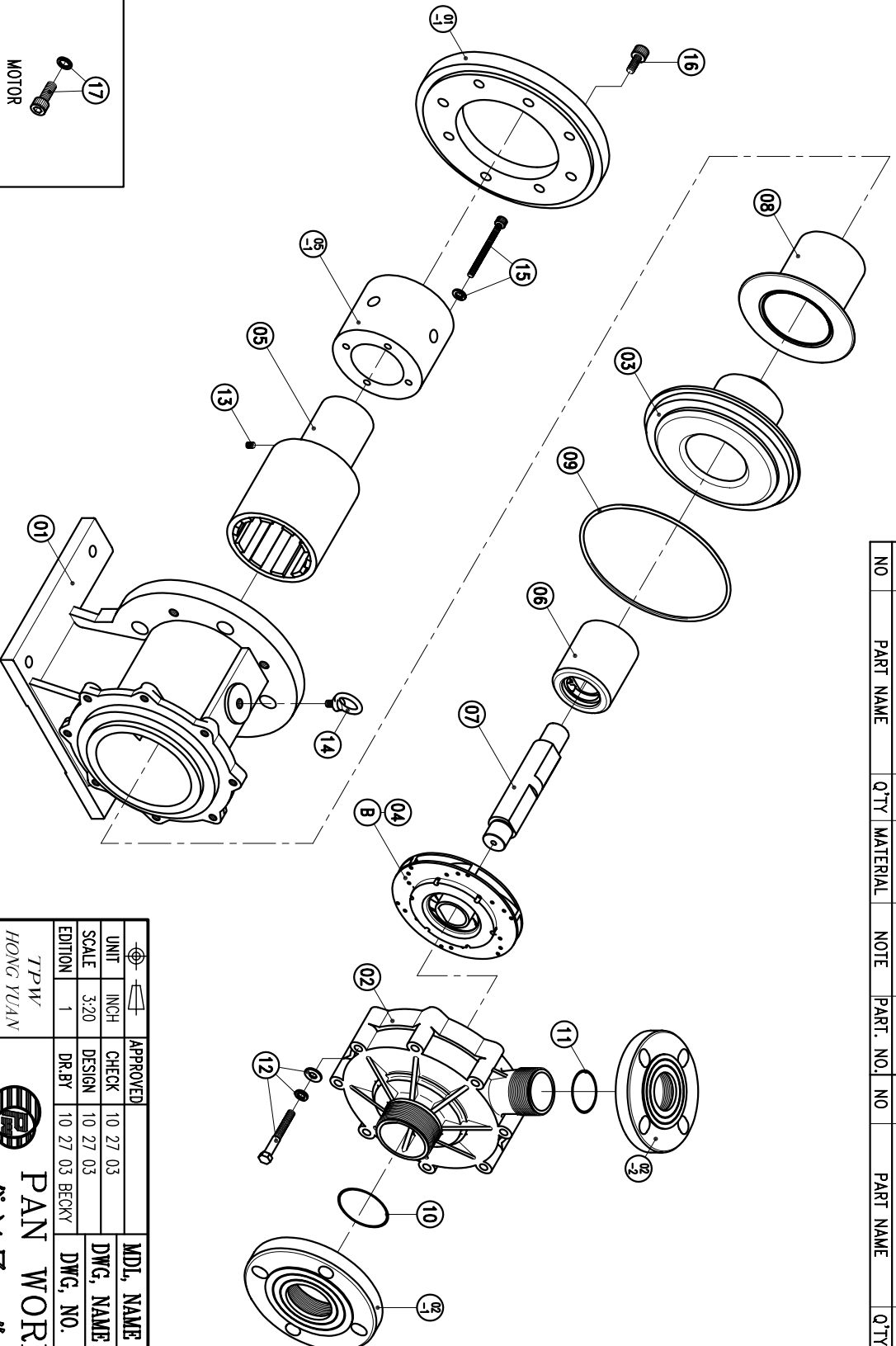

(NEMA)

APPROVED	CHECK	10 27 03	MDL NAME	NH-5013PH (11kW)
CHECK	DESIGN	10 27 03	DWG. NAME	DECOMPOSITION DRAWING
SCALE	DR.BY	10 27 03 BECKY	DWG. NO.	E3508351
EDITION				A3

TPW
HONG YUAN



PAN WORLD CO., LTD.
パンワールド株式会社