

02-1	FLANGE	1	PPG	40A			
02-B	CASING-2ND	1	PPS	φ226.5X59.5			
02-1	FLANGE	1	PPG	50A			
02-A	FRONT CASING-1ST	1	PPS	THRUST PAD: CERAMIC BEARING: CARBON THRUST PAD: SIC BEARING: SIC			
01-1	TRANSITION FLANGE	1	FC-20	φ254X21.6			
01	BRACKET	1	FC-20	φ226.5X205			

09	DEFUSER	1	PPS	φ195X18			
08	REAR CASING COVER	1	CERAMIC	φ158X121			
07	SPINDLE	1	SIC	φ38X198			
06	MAGNET CAPSULE	1	PPG	φ79.6X92			
05-1	FLY WHEEL	1	S45C	φ122X97			
05	DRIVE MAGNET	1	FCD-45	φ122X199			
04-B	IMPELLER ASS'Y-2ND	1	PPS	4026PH			
04-A	IMPELLER ASS'Y-1ST	1	PPS	4024PH			
03	REAR CASING	1	PPS	4026PH CARBON SIC			
18	HEXAGON SOCKET BOLT	4	SUS304	1/2"-13x1 1/4"			
17	HEXAGON SOCKET WASHER	4	SUS304	M12X25			
16	HEXAGON SOCKET BOLT	4	SUS304	M8X90			
15	w/1 SPRING WASHER	1	S41C	M12X20			
14	SET SCREW	2	S435	M8X10			
13	HEXAGON HEAD BOLT	8	SUS304	M10X120			
12	w/1 SPRING WASHER	1	FKM	S40			
11	w/1 PLAIN WASHER	1	FKM	S50			
10	O. RING	2	FKM	G200			

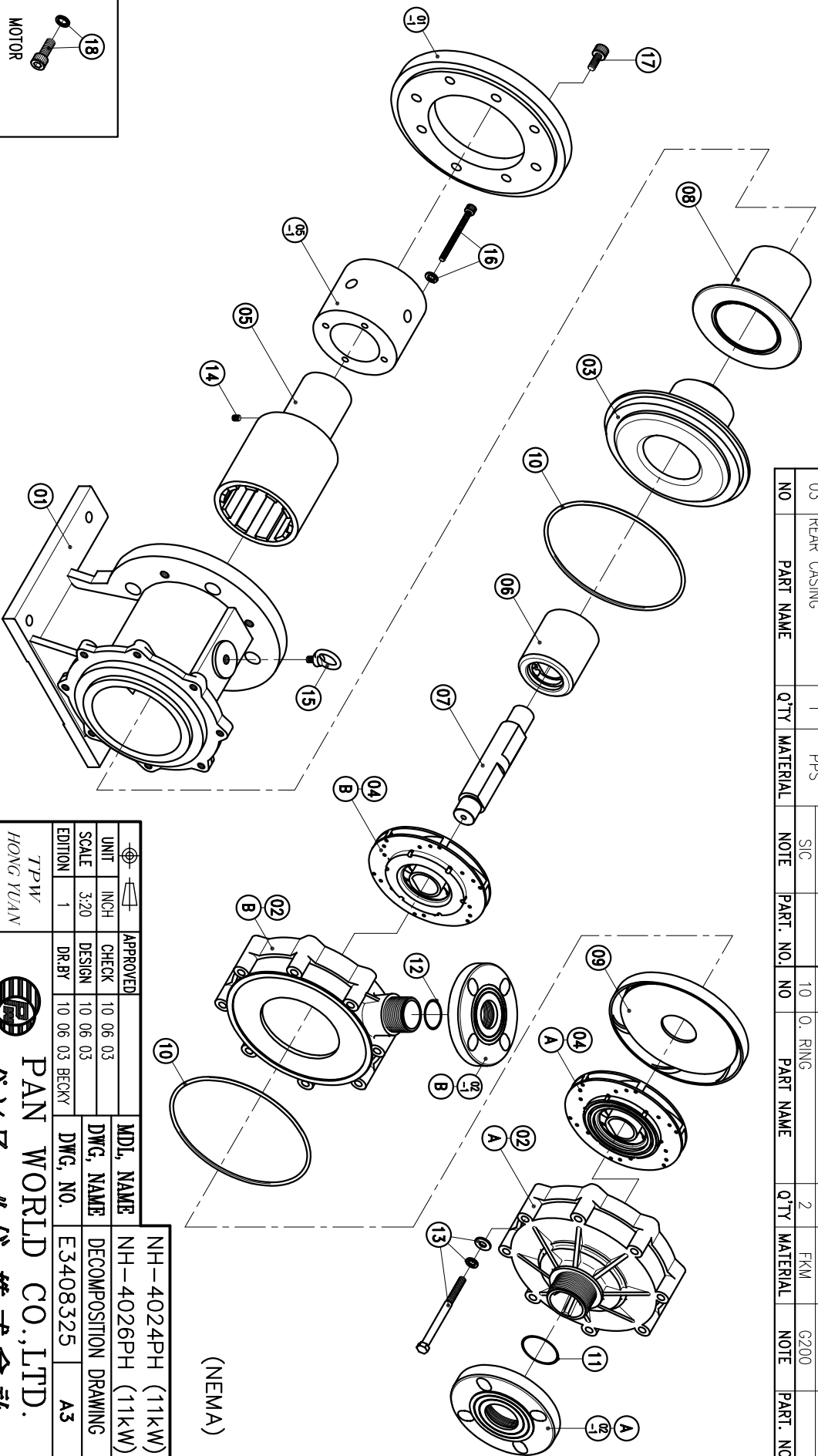

(NEMA)

APPROVED	CHECK	10.06.03	MDL NAME	NH-4024PH (11kW)
DESIGN	SCALE	3:20	DWG. NAME	NH-4026PH (11kW)
DR.BY	EDITION	1	DWG. NO.	E3408325
10.06.03				DECOMPOSITION DRAWING
BECKY			A3	

TPW
HONG YUAN



PAN WORLD CO., LTD.
パンワールド株式会社