

02	FRONT CASING	1	PPS	THRUST PAD: CERAMIC BEARING: CARBON THRUST PAD: SIC		
01	BRACKET	1	FC-20	φ226.5X205		

07	SPINDLE	1	CERAMIC	φ38X156		
06	MAGNET CAPSULE	1	PPG	φ79.6X92		
05-2	RING	1	S45C	φ65X5.7		
05-1	FLY WHEEL	1	S45C	φ122X68		
05	DRIVE MAGNET	1	FCD-45	φ122X199		
04	IMPELLER ASS'Y	1	PPS	4012PPH		
03	REAR CASING	1	PPS	4013PH CARBON SIC		

14	HEXAGON SOCKET BOLT	4	SUS304	1/2"-13X1 1/4"		
13	HEXAGON SOCKET BOLT w/1 SPRING WASHER	4	SUS304	M8X60		
12	EYE BOLT	1	S41C	M12X20		
11	SET SCREW	2	S435	M8X10		
10	HEXAGON HEAD BOLT w/1 SPRING WASHER w/1 PLAN WASHER	8	SUS304	M10X80		
09	O. RING	1	FKM	G200		
08	REAR CASING COVER	1		φ158X121		

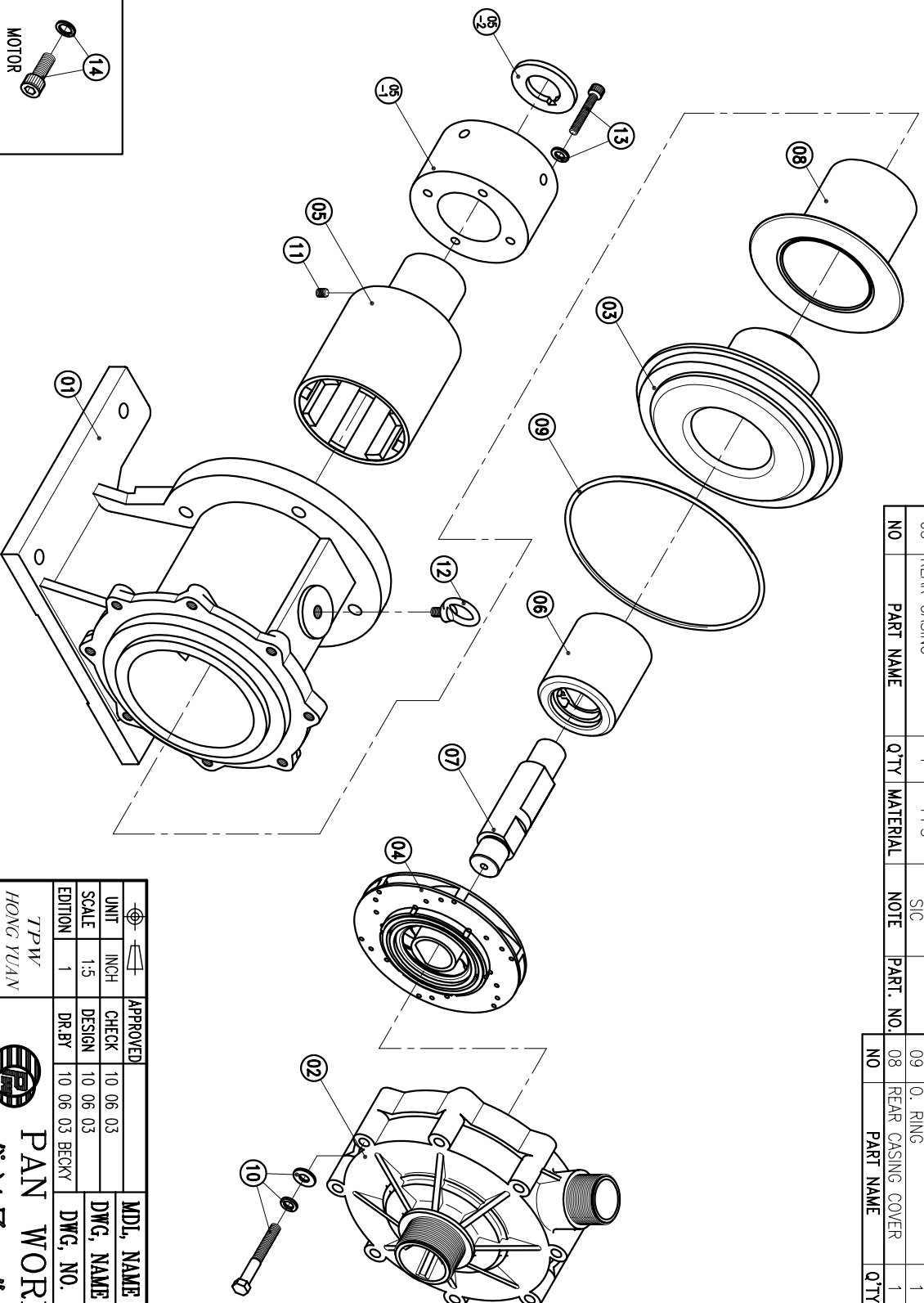

(NEMA)

APPROVED	CHECK	10.06.03	MDL NAME	NH-4012PH (5.5kW)
CHECK	DESIGN	10.06.03	DWG. NAME	NH-4013PH (5.5kW)
DESIGN	DR.BY	10.06.03	DECOMPOSITION DRAWING	
DR.BY	BECKY		DWG. NO.	E3408322
BECKY				A3

TPW  
HONG YUAN



PAN WORLD CO., LTD.  
パンワールド株式会社