

04-1	IMPELLER-1ST	1	PPS	φ170X41	A2418462	08-1	BACK UP RING	1	SUS304	φ158X4	A2118517	18	HEXAGON SOCKET BOLT	4	SUS304	1/2"-13X1 1/4"	
04-A	IMPELLER ASS'Y-1ST	1	PPS	5024PH	A2408527	08	REAR CASING COVER	1	08-1,-2,-3	φ158X121	A2118477	17	HEXAGON SOCKET BOLT	4	SUS304	M12X25	
03-1	BEARING	1	CARBON SIC	φ40X25	A2228423	07	SPINDLE	1	CERAMIC SIC	φ38X198	A2338480	16	HEXAGON SOCKET BOLT	4	SUS304	M8X90	
03	REAR CASING	1	PPS	φ210X123.5	A2308476	06-2	DRIVEN MAGNET	1	Nd-Fe-B	φ76X86	A2448514	15	EYEBOLT	1	S41C	M12X20	
02-1	FLANGE	1	PPG	50A	A2238547	06-1	REAR THRUST PAD	1	CERAMIC SIC	φ48X10	A2328512	14	SET SCREW	2	S435	M8X10	
02-B	CASING-2ND	1	PPS	φ226.5X69.5	A2208516	06	MAGNET CAPSULE	1	PPG	φ79.6X92	A2438472	13	HEXAGON HEAD BOLT	8	SUS304	M10X120	
02-3	FLANGE	1	PPG	65A	A2238559	05-1	FLY WHEEL	1	S45C	φ122X90	A2538577	13	HEXAGON HEAD BOLT	8	SUS304	M10X120	
02-2	BEARING	1	CARBON SIC	φ40X25	A2228423	05	DRIVE MAGNET	1	FCD-45	φ122X230.5	A2508576	12	O. RING	1	FKM	φ49.5Xφ2	
02-1	FRONT THRUST PAD	1	CERAMIC SIC	φ104X9	P2224475	04-3	SHLOUD-2ND	1	PPS	φ170X12	A2458492	11	O. RING	1	FKM	φ64.5Xφ2	
02-A	FRONT CASING-1ST	1	PPS	φ226.5X101	A2208523	04-1	IMPELLER-2ND	1	PPS	φ170X41	A2418462	10	O. RING	2	FKM	φ199.3Xφ5.7	
01-1	TRANSITION FLANGE	1	FC-20	φ254X21.5	P2179309	04-B	IMPELLER ASS'Y-2ND	1	PPS	5024PH	A2408498	09	DEFUSER	1	PPS	φ195X18	
01	BRACKET	1	FC-20	φ226.5X205	A2128575	04-2	MOUTH RING	1	RULON	φ104X9	A2428549	08-3	COVER	1	SUS304	φ90.2X17.5	
NO	PART NAME	Q'TY	MATERIAL	NOTE	DWG. NO.	NO	PART NAME	Q'TY	MATERIAL	NOTE	DWG. NO.	NO	PART NAME	Q'TY	MATERIAL	NOTE	DWG. NO.
08-2	PIPE	1	HASTELLOY C	φ91.4X112	A2118474	08-2	PIPE	1	HASTELLOY C	φ91.4X112	A2118474	08-2	PIPE	1	HASTELLOY C	φ91.4X112	A2118474

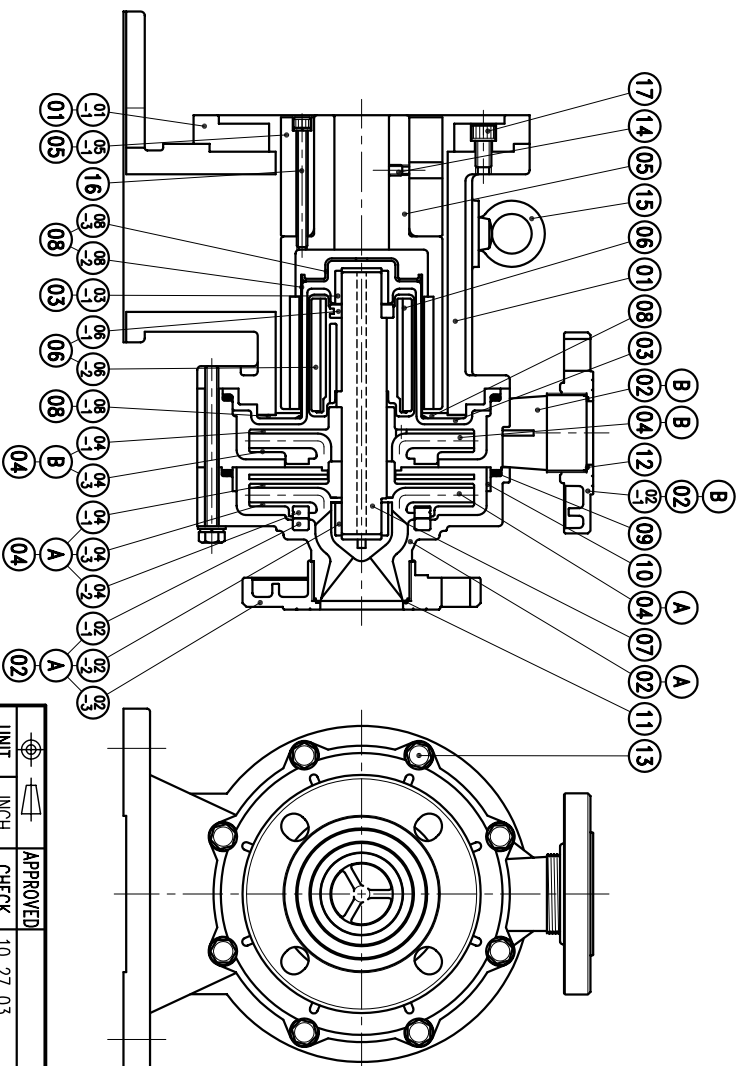

(NEMA)

APPROVED	CHECK	MDL. NAME	NH-5024PH (11kW)
10 27 03	10 27 03	DWG. NAME	CONSTRUCTION DRAWING
DESIGN	DESIGN	DWG. NO.	E2508355
10 27 03 BECKY	10 27 03 BECKY		A3

TPW
HONG YUAN



PAN WORLD CO., LTD.
パンワールド株式会社