

04	IMPELLER ASS'Y	1	PPS	5013PH	A2408581	08-2	PIPE	1	HASTELLOY C	φ91.4X112	A2118474	17	HEXAGON SOCKET BOLT	4	SUS304	1/2"-13X1 1/4"	
			CARBON	φ40X25	A2228423	08-1	BACK UP RING	1	SUS304	φ158X4	A2118517	16	HEXAGON SOCKET BOLT	4	SUS304	M12X25	
03-1	BEARING	1	SIC			08	REAR CASING COVER	1	08-1,-2,-3	φ158X121	A2118477	15	HEXAGON SOCKET BOLT	4	SUS304	M8X90	
03	REAR CASING	1	PPS	φ210X123.5	A2308476	07	SPINDLE	1	CERAMIC	φ38X198	A2338480	14	HEXAGON SOCKET BOLT	1	S41C	M12X20	
02-4	FLANGE	1	PPG	50A	A2238547				SIC			13	SET SCREW	2	S435	M8X10	
02-3	FLANGE	1	PPG	65A	A2238559	06-2	DRIVEN MAGNET	1	Nd-Fe-B	φ76X86	A2448514	12	EYEBOLT	1	SUS304	M10X80	
02-2	BEARING	1	CARBON	φ40X25	A2228423	06-1	REAR THRUST PAD	1	CERAMIC	φ48X10	A2338512	11	HEXAGON HEAD BOLT	8	SUS304	M10X80	
			SIC			06	MAGNET CAPSULE	1	PPG	φ79.6X92	A2438472	10	RING	1	FKM	φ49.5Xφ2	
02-1	FRONT THRUST PAD	1	CERAMIC	φ104X9	P2224475	05-1	FLY WHEEL	1	S45C	φ122X90	A2538577	9	RING	1	FKM	φ64.5Xφ2	
			SIC			05	DRIVE MAGNET	1	FCD-45	φ122X230.5	A2508576	8	RING	1	FKM	φ199.3Xφ5.7	
02	FRONT CASING	1	PPS	φ226.5X118.5	A2208546	04-3	SHLOUD	1	PPS	φ170X12	A2458481	7	RING	1	FKM	φ90.2X17.5	
01-1	TRANSITION FLANGE	1	FC-20	φ254X21.5	P2179309	04-2	MOUTH RING	1	RULON	φ104X9	A2428549	6	RING	1	SUS304	φ90.2X17.5	
01	BRACKET	1	FC-20	φ226.5X205	A2128575	04-1	IMPELLER	1	PPS	φ170X41	A2418482	5	COVER	1	SUS304	φ90.2X17.5	
NO	PART NAME	Q'TY	MATERIAL	NOTE	DWG. NO.	NO	PART NAME	Q'TY	MATERIAL	NOTE	DWG. NO.	NO	PART NAME	Q'TY	MATERIAL	NOTE	DWG. NO.

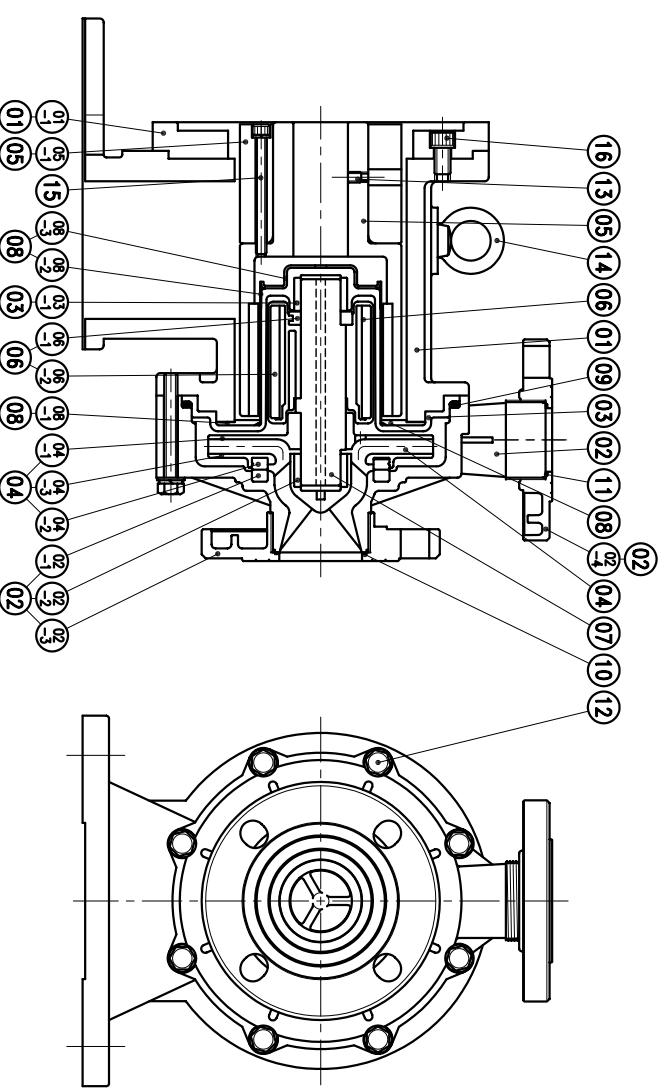

(NEMA)

APPROVED	CHECK	10 27 03	MDL NAME	NH-5013PH	(11kW)
SCALE	DESIGN	10 27 03	DWG. NAME	CONSTRUCTION	DRAWING
EDITION	DR.BY	10 27 03 BECKY	DWG. NO.	E2508354	A3

TPW
HONG YUAN



PAN WORLD CO., LTD.
パンワールド株式会社