

04	IMPELLER ASS'Y	1	PPS	5012PH	A2408581	08-1	BACK UP RING	1	SUS304	φ158X4	A2118517	16	HEXAGON SOCKET BOLT	4	SUS304	1/2"-13X1 1/4"	
				5013PH		08	REAR CASING COVER	1	08-1,-2,-3	φ158X121	A2118477	15	HEXAGON SOCKET BOLT	4	SUS304	M8X60	
03-1	BEARING	1	CARBON SIC	φ40X25	A2228423	07	SPINDLE	1	CERAMIC SIC	φ38X156	A2338480	14	HEXAGON SOCKET BOLT	4	SUS304	M8X60	
03	REAR CASING	1	PPS	φ210X123.5	A2308476	06-2	DRIVEN MAGNET	1	Nd-Fe-B	φ76X86	A2448506	13	SET SCREW	2	S435	M12X20	
02-4	FLANGE	1	PPG	50A	A2238547	06-1	REAR THRUST PAD	1	CERAMIC SIC	φ48X10	A2328512	12	HEXAGON HEAD BOLT	8	SUS304	M10X80	
02-3	FLANGE	1	PPG	65A	A2238559	06	MAGNET CAPSULE	1	PPG	φ79.6X69.5	A2438472	11	W/T P.W.(φ21Xφ10.5X12)	1	FKM	φ49.5Xφ2	
02-2	BEARING	1	CARBON SIC	φ40X25	A2228423	05-2	RING	1	S45C	φ65X5.7	P2574346	10	O. RING	1	FKM	φ64.5Xφ2	
02-1	FRONT THRUST PAD	1	CERAMIC SIC	φ104X9	P2224475	05-1	FLY WHEEL	1	S45C	φ122X68	A2538511	09	O. RING	1	FKM	φ199.3Xφ5.7	
02	FRONT CASING	1	PPS	φ226.5X118.5	A2208546	05	DRIVE MAGNET	1	FCD-45	φ122X199	A2508564	08-3	COVER	1	SUS304	φ90.2X17.5	
01	BRACKET	1	FC-20	φ226.5X184.5	A2128563	04-2	MOUTH RING	1	RUION	φ104X9	A2428549	08-2	PIPE	1	HASTELLOY C	φ91.4X112	
NO	PART NAME	Q'TY	MATERIAL	NOTE	DWG. NO.	NO	PART NAME	Q'TY	MATERIAL	NOTE	DWG. NO.	NO	PART NAME	Q'TY	MATERIAL	NOTE	DWG. NO.

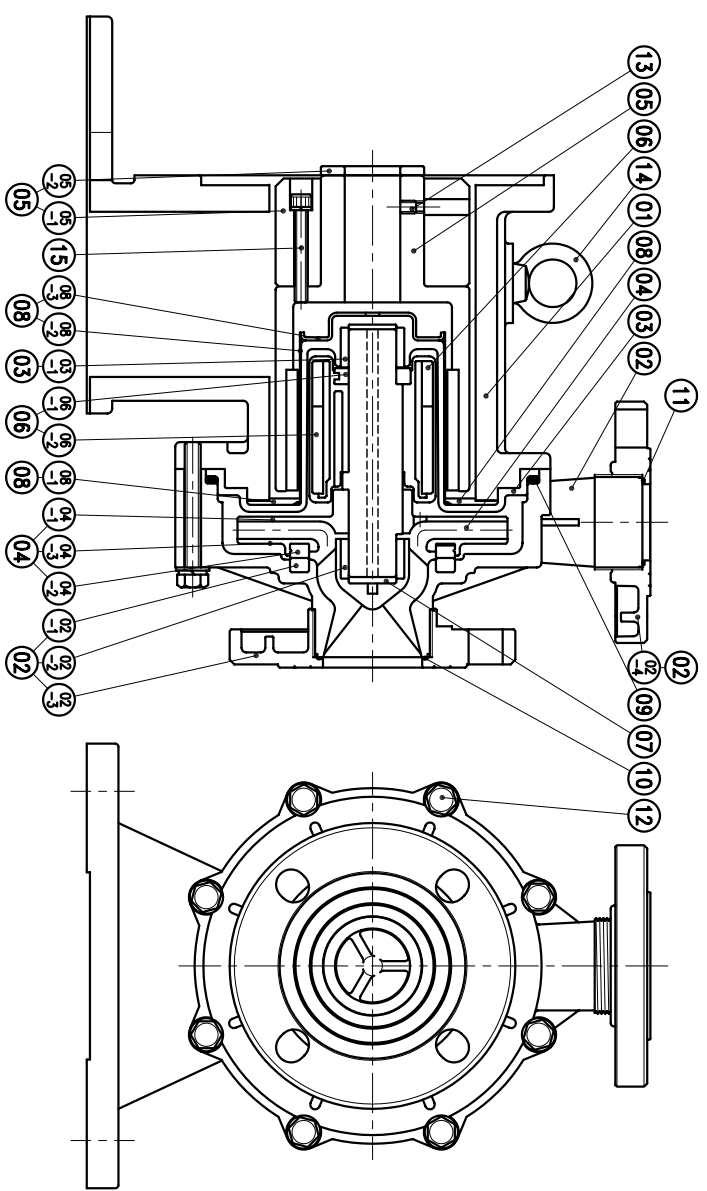

(NEMA)

UNIT	INCH	CHECK	10 24 03	MDL NAME	NH-5012PH (7.5KW)
SCALE	3:10	DESIGN	10 24 03	DWG. NAME	NH-5013PH (7.5KW)
EDITION	1	DR.BY	10 24 03 BECKY	DWG. NO.	E2508352
					A3

TPW
HONG YUAN

PAN WORLD CO., LTD.
パンワールド株式会社