

04	IMPELLER ASS'Y	1	PPS	5012PH	A2408581	08-1	BACK UP RING	1	SUS304	φ158X4	A2118517	16	HEXAGON SOCKET BOLT	4	SUS304	1/2"-13X1 1/4"
				5013PH		08	REAR CASING COVER	1	08-1,-2,-3	φ158X121	A2118477					
03-1	BEARING	1	CARBON SIC	φ40X25	A2228423	07	SPINDLE	1	CERAMIC SIC	φ38X156	A2338480	15	HEXAGON SOCKET BOLT	4	SUS304	M8X60
03	REAR CASING	1	PPS	φ210X123.5	A2308476	06-2	DRIVEN MAGNET	1	Nd-Fe-B	φ76X86	A2448494	14	EBEBOLT	1	S41C	M12X20
02-4	FLANGE	1	PPG	50A	A2238547	06-1	REAR THRUST PAD	1	CERAMIC SIC	φ48X10	A2328512	13	SET SCREW	2	S435	M8X10
02-3	FLANGE	1	PPG	65A	A2238559											
02-2	BEARING	1	CARBON SIC	φ40X25	A2228423	06	MAGNET CAPSULE	1	PPG	φ79.6X69.5	A2438472	12	HEXAGON HEAD BOLT	8	SUS304	M10X80
						05-2	RING	1	S45C	φ65X5.7	P2574346					
02-1	FRONT THRUST PAD	1	CERAMIC SIC	φ104X9	P2224475	05-1	FLY WHEEL	1	S45C	φ122X68	A2538511	11	O. RING	1	FKM	φ49.5Xφ2
						05	DRIVE MAGNET	1	FCD-45	φ122X199	A2508572	10	O. RING	1	FKM	φ64.5Xφ2
02	FRONT CASING	1	PPS	φ226.5X118.5	A2208546	04-3	SHLOUD	1	PPS	φ170X12	A2458481	09	O. RING	1	FKM	φ199.3Xφ5.7
01	BRACKET	1	FC-20	φ226.5X184.5	A2128571	04-2	MOUTH RING	1	RULON	φ104X9	A2428549	08-3	COVER	1	SUS304	φ90.2X17.5
						04-1	IMPELLER	1	PPS	φ170X41	A2418482	08-2	PIPE	1	HASTELLOY C	φ91.4X112

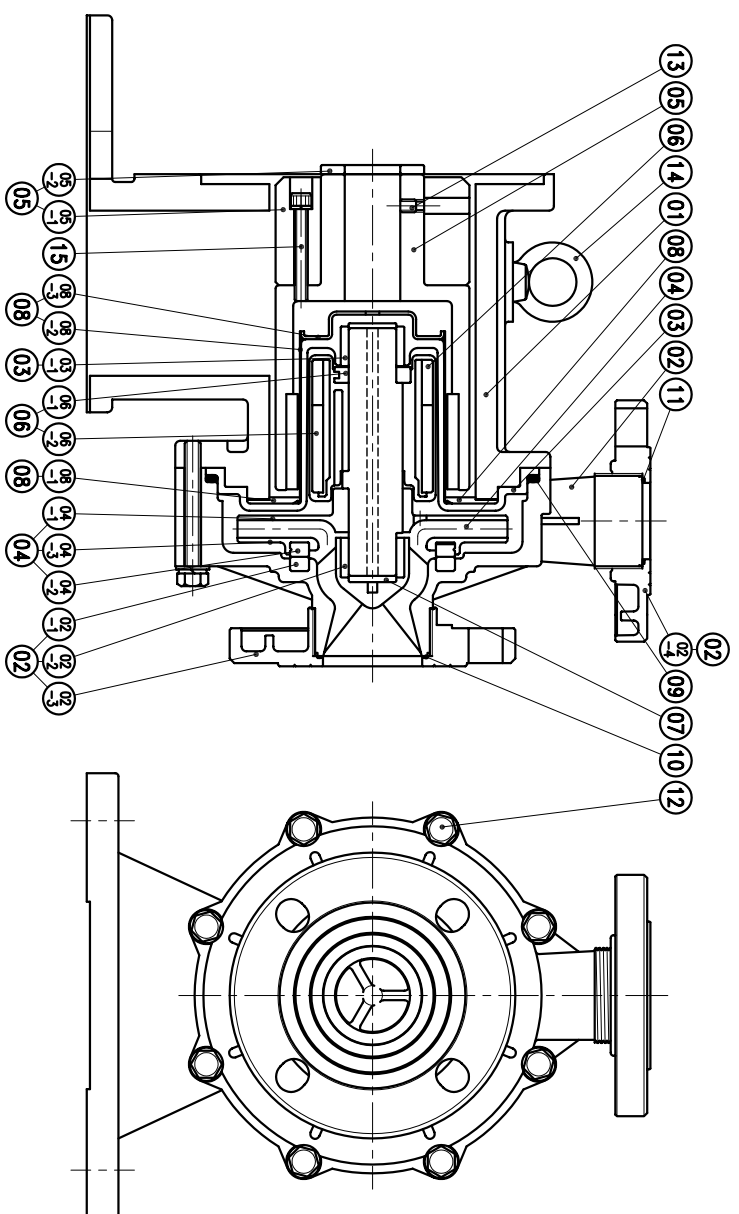

(NEMA)

APPROVED	CHECK	DESIGN	DR.BY	MDL. NAME	DWG. NAME	DWG. NO.
10 24 03	10 24 03	10 24 03	10 24 03 BECKY	NH-5012PH (5.5KW)	NH-5013PH (5.5KW)	E2508350
UNIT	SCALE	EDITION		CONSTRUCTION	DRAWING	A3
INCH	3:10	1				

TPW  
HONG YUAN

PAN WORLD CO., LTD.  
パンワールド株式会社