

03-1	BEARING	1	CARBON	08	REAR CASING COVER	1	08-1,-2,-3	0158X121	A2118477	16	HEXAGON SOCKET BOLT	4	SUS304	1/2"-13X3/4"			
			SIC								w/1 S.W.(1/2")						
03	REAR CASING	1	PPS	07	SPINDLE	1	CERAMIC	038X156	A2338480	15	COUNTER SUNK HEAD BOLT	4	S435	M10X25	P9119375		
			0210X123.5	A2308476			SIC				SET SCREW	2	S435	M6X10	P9116430		
02-4	FLANGE	1	PPG	06-2	DRIVEN MAGNET	1	Nd-Fe-B	076X86	A2448531	14	SET SCREW	2	S435	M6X10	P9119160		
02-3	FLANGE	1	PPG	06-1	REAR THRUST PAD	1	CERAMIC	048X10	A2338512	13	SET SCREW	2	S435	M8X10	P9119160		
02-2	BEARING	1	CARBON	06-1	REAR THRUST PAD	1	SIC				HEXAGON HEAD BOLT	8	SUS304	M10X80	P9113080		
			040X25	A2228423				079.6X92	A2438472	12	w/1 S.W.(M10)						
02-1	FRONT THRUST PAD	1	CERAMIC	05	MAGNET CAPSULE	1	PPG	048X9.8	P2509342		w/1 P.W.(021X010.5X12)						
			0104X9	P2224475			S45C			11	O. RING	1	FKM	049.5X02	S50		
02	FRONT CASING	1	PPS	04-3	SHLOUD	1	PPS	0170X12	A2458481	10	O. RING	1	FKM	064.5X02	S65		
			0226.5X118.5	A2208546				0104X9	A2428549	09	O. RING	1	FKM	0199.3X05.7	G200		
01-1	TRANSITION FLANGE	1	FC-20	04-2	MOUTH RING	1	RULON	0104X9	A2418462	08-3	COVER	1	SUS304	090.2X17.5	A2118518		
			0226.5X183.5	A2128569				0170X41	A2418462	08-2	PIPE	1	HASTELLOY C	091.4X112	A2118474		
01	BRACKET	1	FC-20	04	IMPELLER ASS'Y	1	PPS	5012PH	A2408581	08-1	BACK UP RING	1	SUS304	0158X4	A2118517		
NO	PART NAME	Q'TY	MATERIAL	NOTE	DWG. NO.	NO	PART NAME	Q'TY	MATERIAL	NOTE	DWG. NO.	NO	PART NAME	Q'TY	MATERIAL	NOTE	DWG. NO.

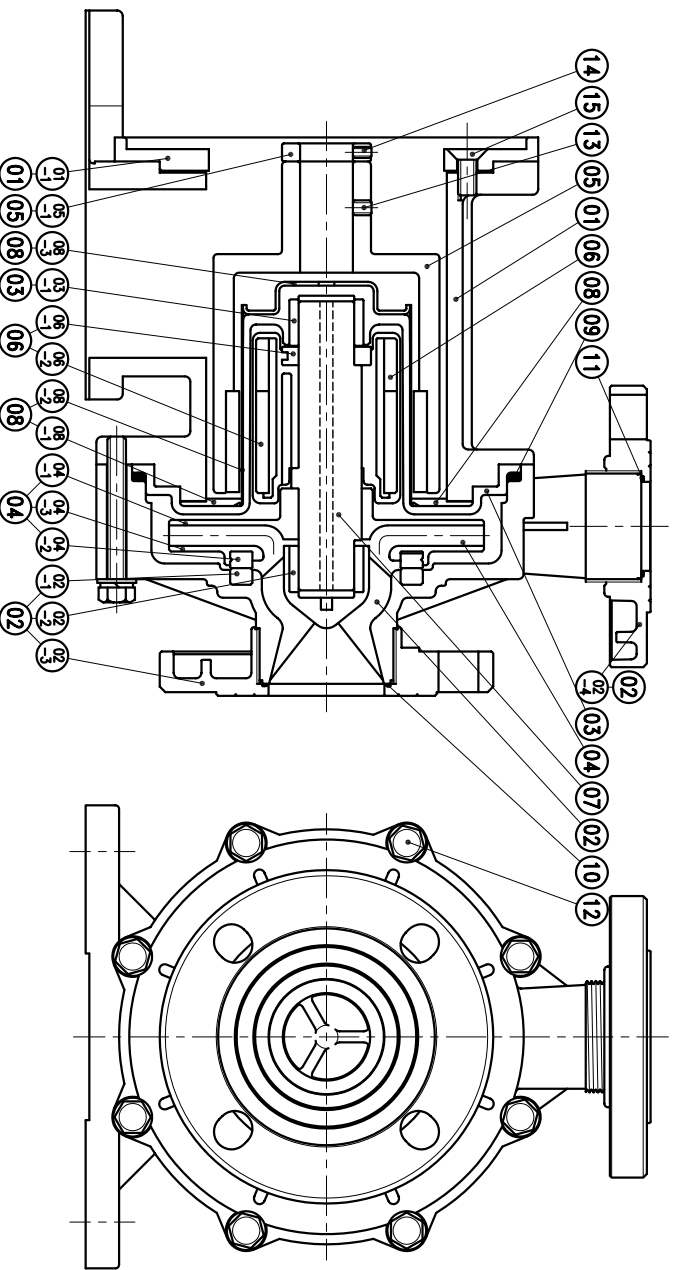

(NEMA)

APPROVED		MDL NAME	NH-5012PH (3.7kW)
CHECK	10.24.03	DWG. NAME	CONSTRUCTION DRAWING
DESIGN	10.24.03	DWG. NO.	E2508349
DR.BY	10.24.03 BECKY		A3

TPW  
HONG YUAN



PAN WORLD CO., LTD.  
パンワールド株式会社