

NO	PART NAME	QTY	MATERIAL	NOTE	DWG NO.	NO	PART NAME	QTY	MATERIAL	NOTE	DWG NO.	NO	PART NAME	QTY	MATERIAL	NOTE	DWG NO.
06-2	BEARING	1	SIC	φ40X42	P2466396	18	SET SCREW	2	S435	M8X10		35	SPRING WASHER	1	SUS316	M10	
06-1	HOUSING, BEARING	1	SUS316	φ76X36	P2466398	17	O. RING	1	FKM	φ209.3Xφ5.7	G210	34	SPRING WASHER	2	SUS316	M12	
06	BEARING ASS'Y	1		φ76X42	P2466406	16	O. RING	1	FKM	φ99.4Xφ3.1	G100	33	HEXAGON SOCKET BOLT	3	SUS304	M12X45	
05-1	FLY WHEEL	1	S45C	φ139X75	P2536439	15	O. RING	1	FKM	φ34.4Xφ3.1	G35						
05	OUTER DRIVE RING	1	FCD-45	φ122X202.5	A2506201	14-2	REAR THRUST PAD	1	SIC	φ40X7	P2426390	32	HEXAGON SOCKET BOLT	6	SUS304	M12X40	
						14-1	HOUSING, THRUST PAD	1	SUS316	φ76X8	P2426389	31	HEXAGON SOCKET BOLT	4	SUS304	M10X35	
						14	THRUST PAD ASS'Y	1									
						13	CENTER PLATE	1	SUS316	φ225X22	P2616385	30	HEXAGON SOCKET BOLT	3	SUS304	M8X60	
						12	REAR SLEEVE	1	SIC	φ35X10	A2376183						
						11	REAR SLEEVE HOLDER	1	SUS316	φ66X34.5	P2376928	29	HEXAGON SOCKET BOLT	6	SUS304	M6X12	
						10	FIXING PLATE	1	SUS316	φ32X8	P2376407						
						09	SLEEVE	1	SIC	φ6X40	P2466397	28	HEXAGON SOCKET BOLT	4	SUS316	M6X10	
						08	SPINDLE	1	SUS316	φ22X152	P2336455	27	HEXAGON SOCKET BOLT	6	SUS316	M6X8	
03-3	REAR CASING COVER	1	SUS316	φ86X10.5	P2376395	07-7	INNER MG. HOUSING PIPE	1	SUS316	φ77.2X90.5	P2476408	26	HEXAGON HEAD BOLT	1	SUS316	1/4"-20X3/4"	
03-2	REAR CASING PIPE	1	SUS316	φ86X111.5	P2376442	07-6	INNER MG. HOUSING COVER	1	SUS316	φ76X3	P2476402	25	HEXAGON HEAD BOLT	4	SUS304	M6X6	
03-1	REAR CASING RING	1	SUS316	φ150X11.9	P2316393	07-5	REAR BEARING COVER	1	SUS316	φ77X10.5	A2476256	24	KEY	1	SUS316	6X6X25	
03	REAR CASING ASS'Y	1		φ150X125.5	P2306929	07-4	REAR BEARING	1	SIC	φ47X10	A2466182	23	KEY	1	SUS316	5X5X20	
02	FRONT CASING	1	SUS316	ANSI 300lbs	P2216523	07-3	INNER MAGNET	1	Nd-Fe-B	φ76X77.5	P2446446	22	IMPELLER NUT	1	SUS316	M12(L)	
01-2	TRANSITION FLANGE	1	FC-20	φ228.6X75.7	A2176218	07-2	INNER MAGNET HOUSING	1	SUS316	φ76X98.5	P2436448	21	IMPELLER NUT	1	SUS316	M12(R)	
01-1	FOOT	1	FCD-45	280X195	P2179157	07-1	THRUST PAD	1	SIC	φ40X7	P2426976	20	IMPELLER NUT	1	SUS316	M12	
01	BRACKET	1	FC-20	φ270X144	A2126196	07	INNER DRIVE RING	1	SIC	φ177.2X98.5	P2436451	19	EYE BOLT	1	S41C	M12X20	

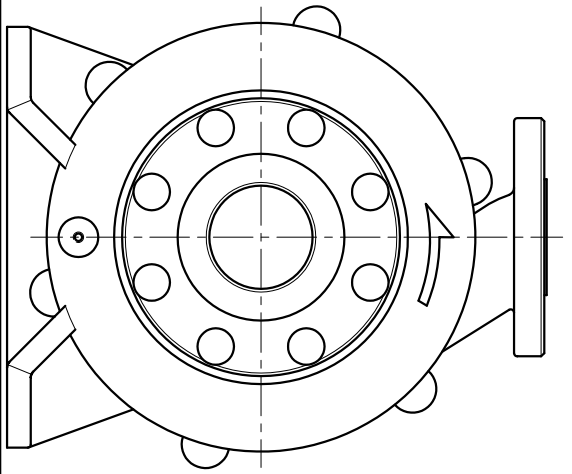
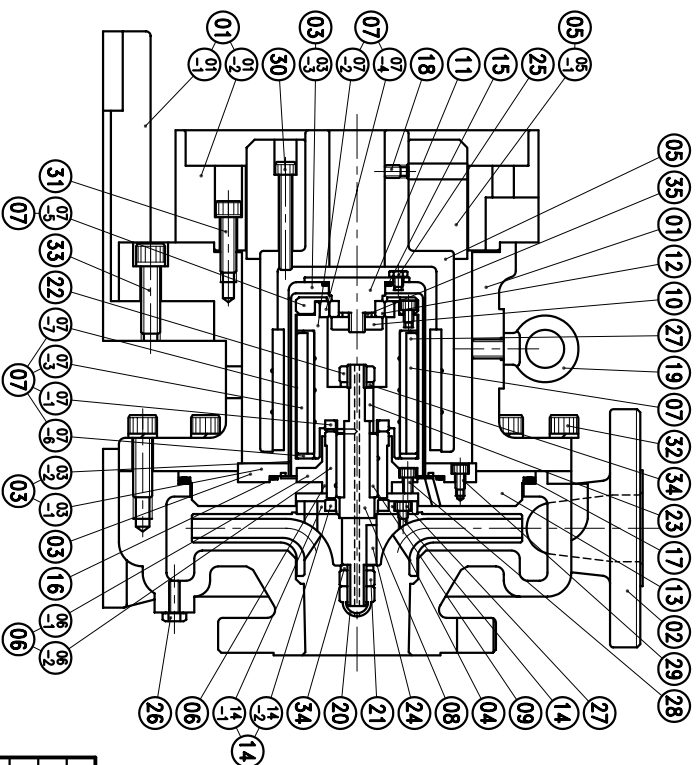

APPROVED	12 12 02	MDL NAME	NH-40-100PG
CHECK	12 12 02	DWG. NAME	NH-40-120PG
DESIGN	10 04 99	CONSTRUCTION DRAWING	NH-40-180PG
DR.BY	12 12 02 BECKY	DWG. NO.	B2406694
EDITION	1		A3

TPW  
HONG YUAN

**PAN WORLD CO., LTD.**  
パナワールド 株式会社