

NO	PART NAME	Q'TY	MATERIAL	NOTE	DWG NO.	NO	PART NAME	Q'TY	MATERIAL	NOTE	DWG NO.
07-2	INNER MAGNET HOUSING	1	SUS316	φ76X82.5	P2436447	19	EYE BOLT	1	S41C	M12X20	
07-1	THRUST PAD	1	SIC	φ40X7	P2426976	18	SET SCREW	2	S435	M8X10	
07	INNER DRIVE RING	1	SIC	φ77.2X82.5	P2436399	17	O. RING	1	FKM	φ209.3Xφ5.7	G210
06-2	BEARING	1	SIC	φ40X42	P2466396	16	O. RING	1	FKM	φ99.4Xφ3.1	G100
06-1	HOUSING, BEARING	1	SUS316	φ76X36	P2466398	15	O. RING	1	FKM	φ34.4Xφ3.1	G35
06	BEARING ASS'Y	1	S45C	φ76X42	P2466406	14-2	REAR THRUST PAD	1	SIC	φ40X7	P2426390
05-1	FLY WHEEL	1	S45C	φ139X55	P2536405	14-1	HOUSING, THRUST PAD	1	SUS316	φ76X8	P2426389
05	OUTER DRIVE RING	1	FCD-45	φ122X172	A2506198	14	THRUST PAD ASS'Y	1	SUS316	φ76X9	P2426388
04	IMPELLER	1	SUS316	120PG, φ120X40 140PG, φ140X40	P2416383	13	CENTER PLATE	1	SUS316	φ225X22	P2616385
03-3	REAR CASING COVER	1	SUS316	φ86X10.5	P2376395	12	REAR SLEEVE	1	SIC	φ35X10	A2376183
03-2	REAR CASING PIPE	1	SUS316	φ86X96	P2376444	11	REAR SLEEVE HOLDER	1	SUS316	φ66X34.5	P2376928
03-1	REAR CASING RING	1	SUS316	φ150X11.9	P2376393	10	FIXING PLATE	1	SUS316	φ32X8	P2376407
03	REAR CASING ASS'Y	1	φ150X11.0	P2306443	08	SPINDLE	1	SUS316	φ22X152	P2336455	
02	FRONT CASING	1	SUS316	ANSI 300lb	P2216519	07-7	INNER MG. HOUSING PIPE	1	HASTELLOY C	φ77.2X74.5	P2476449
01-2	TRANSITION FLANGE	1	FC-20	φ228.6X47	A2176197	07-6	INNER MG. HOUSING COVER	1	SUS316	φ76X3	P2476402
01-1	FOOT	1	FCD-45	280X195	P2179157	07-5	REAR BEARING COVER	1	SUS316	φ77X10.5	A2476256
01	BRACKET	1	FC-20	φ270X144	A2126196	07-4	REAR BEARING	1	SIC	φ47X10	A2466182
						07-3	INNER MAGNET	1	ND-FE-B	φ76X61.5	P2446401
						21	IMPELLER NUT	20	SUS316	M12(R)	
						20	IMPELLER NUT	1	SUS316	M12	
						22	IMPELLER NUT	1	SUS316	M12(L)	
						23	KEY	1	SUS316	5X5X20	
						24	KEY	1	SUS316	6X6X25	
						25	HEXAGON HEAD BOLT	4	SUS304	M6X6	
						26	HEXAGON HEAD BOLT	1	SUS316	1/4"-20X3/4"	
						27	HEXAGON SOCKET BOLT	6	SUS316	6X6X8	
						28	HEXAGON SOCKET BOLT	4	SUS316	M6X10	
						29	HEXAGON SOCKET BOLT	6	SUS304	M6X12	
						30	HEXAGON SOCKET BOLT	3	SUS304	M8X40	
						31	HEXAGON SOCKET BOLT	4	SUS304	M10X35	
						32	HEXAGON SOCKET BOLT	6	SUS304	M12X40	
						33	HEXAGON SOCKET BOLT	3	SUS304	M12X45	
						34	SPRING WASHER	2	SUS316	M12	
						35	SPRING WASHER	1	SUS316	M10	

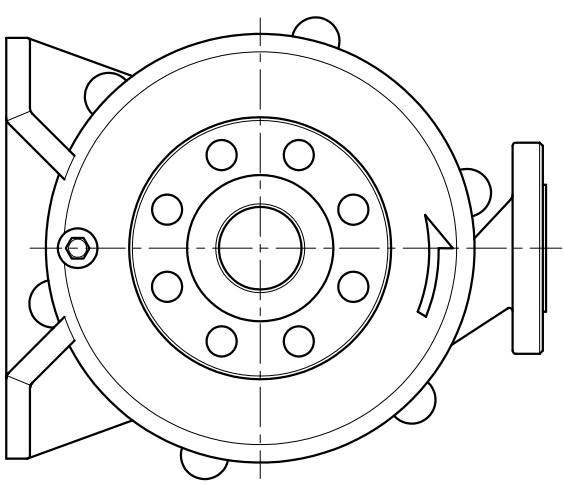
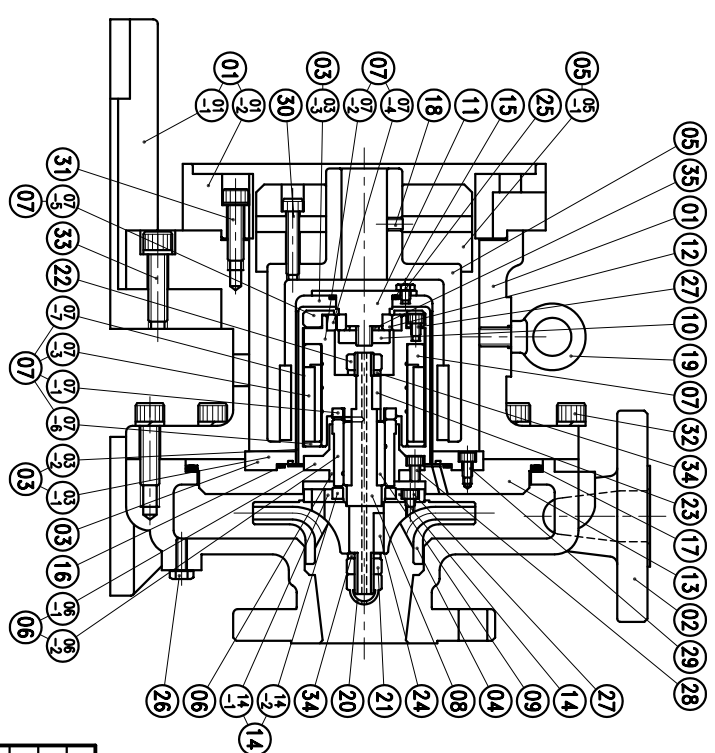

APPROVED	12 12 02	MDL NAME	NH-32-100PG	NH-32-140PG
CHECK	10 04 99	DWG. NAME	CONSTRUCTION DRAWING	
DESIGN	12 12 02	DWG. NO.	B2326294	A3
DR.BY				

TPW  
HONG YUAN

PAN WORLD CO., LTD.  
パナワールド株式会社